

OPERATOR'S / SERVICE MANUAL AND PARTS CATALOG

FOR

SERIES

CCKA

INDUSTRIAL ENGINES

MODELS

CCKA-MS/1831G

CCKA-MS/1897G

CCKA-MS/1949G

CCKA-MS/2043G

CCKA-MS/2111G

CCKA-MS/2567G

CCKA-MS/2813J

CCKA-MS/3110J

CCKA-MS/3612J

SAFETY PRECAUTIONS

The following symbols in this manual signal potentially dangerous conditions to the operator or equipment. Read this manual carefully. Know when these conditions can exist. Then, take necessary steps to protect personnel as well as equipment.

WARNING Onan uses this symbol throughout this manual to warn of possible serious personal injury.

CAUTION This symbol refers to possible equipment damage.

Fuels, electrical equipment, batteries, exhaust gases and moving parts present potential hazards that could result in serious, personal injury. Take care in following these recommended procedures.

- **Use Extreme Caution Near Gasoline. A constant potential explosive or fire hazard exists.**

Do not fill fuel tank near unit with engine running. Do not smoke or use open flame near the unit or the fuel tank.

Be sure all fuel supplies have a positive shutoff valve.

Fuel lines must be of steel piping, adequately secured and free of leaks. Use a flexible section of fuel line between generator set and stationary fuel line in the vehicle. This flexible section must be 100% NON-METALLIC to prevent electrical currents from using it as a conductor.

Have a fire extinguisher nearby. Be sure extinguisher is properly maintained and be familiar with its proper use. Extinguishers rated ABC by the NFPA are appropriate for all applications. Consult the local fire department for the correct type of extinguisher for various applications.

- **Guard Against Electric Shock**

Remove electric power before removing protective shields or touching electrical equipment. Use rubber insulative mats placed on dry wood platforms over floors that are metal or concrete when around electrical equipment. Do not wear damp clothing (particularly wet shoes) or allow skin surfaces to be damp when handling electrical equipment.

Jewelry is a good conductor of electricity and should be removed when working on electrical equipment.

Always use an appropriately sized, approved double-throw transfer switch with any standby generator set. **DO NOT PLUG PORTABLE OR STANDBY SETS DIRECTLY INTO A HOUSE RECEPTACLE TO PROVIDE EMERGENCY POWER.** It is possible for current to flow from generator into the utility line. This creates extreme hazards to anyone working on lines to restore power.

Use extreme caution when working on electrical components. High voltages cause injury or death.

Follow all state and local electrical codes. Have all electrical installations performed by a qualified licensed electrician.

- **Do Not Smoke While Servicing Batteries**

Lead acid batteries emit a highly explosive hydrogen gas that can be ignited by electrical arcing or by smoking.

- **Exhaust Gases Are Toxic**

Provide an adequate exhaust system to properly expel discharged gases. Check exhaust system regularly for leaks. Ensure that exhaust manifolds are secure and not warped.

Be sure the unit is well ventilated.

- **Keep The Unit And Surrounding Area Clean**

Remove all oil deposits. Remove all unnecessary grease and oil from the unit. Accumulated grease and oil can cause overheating and subsequent engine damage and may present a potential fire hazard.

Do NOT store anything in the generator compartment such as oil cans, oily rags, chains, wooden blocks etc. A fire could result or the generator set operation may be adversely affected. Keep the floor clean and dry.

- **Protect Against Moving Parts**

Avoid moving parts of the unit. Loose jackets, shirts or sleeves should not be permitted because of the danger of becoming caught in moving parts.

Make sure all nuts and bolts are secure. Keep power shields and guards in position.

If adjustments *must* be made while the unit is running, use extreme caution around hot manifolds, moving parts, etc.

Do not work on this equipment when mentally or physically fatigued.

TABLE OF CONTENTS

TITLE	PAGE
General Information	2
Specifications	3
Dimensions and Clearances	4
Assembly Torques	5
Troubleshooting	6
Operation	7
Periodic Maintenance	9
Engine Disassembly	12
Oil System	22
Fuel System	23
Ignition and Battery Charging	26
Starting System	29
Parts Catalog	34
Wiring Diagrams	48

GENERAL INFORMATION

YOUR MANUAL

The manual contains operation, maintenance, troubleshooting, service information, and a parts catalog for the CCKA engine. Keep the manual in a handy location and refer to it often.

Throughout the text, engine end with the flywheel is considered engine front. Left and right are determined when facing the front of the engine.

ENGINE MODEL REFERENCE

Some instructions in this manual refer to specific models of industrial engines. Identify the model by referring to the model number as shown on the unit nameplate.

How to interpret a typical MODEL NUMBER

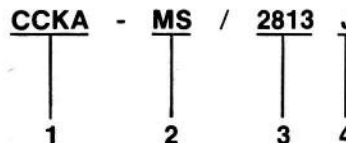

1. Factory code for general identification purposes.
2. Specific Type:
MS-ELECTRIC starting with stub shaft, starter and generator.
3. Factory code for optional equipment supplied.
4. Specification (Spec letter) advances with factory production modification.

WARNING

ENGINE EXHAUST GAS (CARBON MONOXIDE) IS DEADLY!

Carbon monoxide is an odorless, colorless gas formed by incomplete combustion of hydrocarbon fuels. Carbon monoxide is a dangerous gas that can cause unconsciousness and is potentially lethal. Some of the symptoms or signs of carbon monoxide inhalation are:

- Dizziness
- Intense Headache
- Weakness and Sleepiness
- Vomiting
- Muscular Twitching
- Throbbing in Temples

If you experience any of the above symptoms, get out into fresh air immediately.

The best protection against carbon monoxide inhalation is a regular inspection of the complete exhaust system. If you notice a change in the sound or appearance of exhaust system, shut the unit down immediately and have it inspected and repaired at once by a competent mechanic.

SPECIFICATIONS

All clearances given at room temperature of 70° F (21° C)

All dimensions in inches unless otherwise specified (metric equivalents in parentheses where applicable).

Type	4 cycle, Air Cooled
Fuel	Gasoline
Rated Power @ 3600 r/m.....	16.5 HP (12.3 kw)
No. of Cylinders.....	2
Displacement.....	49.8 in. ³ (816 cm ³)
Stroke	3.000 inches (76.2 mm)
Bore	3.250 inches (82.6 mm)
Compression (sea level).....	100-120 psi (7.03-8.44 kg/sq cm)
Crankshaft	Horizontal, Ductile Iron
Valve Lifters	Mechanical
Bearings (main and rod)	Sleeve
Oil Capacity including 1/2 qt. (0.47 l) for filter.....	2-1/2 U.S. Quarts (3.31 litres)
Lubrication System	Full Pressure
Ignition	Battery
Cooling Air Volume at 3600 rpm	830 cfm (23.5 m ³ /min.)
Governor Type	Adjustable, mechanical flyball
Fuel Pump Type.....	Diaphragm
Fuel Pump Lift	4 feet (1.22 m)

Tune-Up Specifications

Breaker Point Gap (full separation)	0.020 (0.508 mm)
Spark Plug Gap	0.025 (0.635 mm)
Ignition Timing	19° BTC
Carburetor Float Clearance (between float bowl gasket and float)	5/16 (7.9 mm)

DIMENSIONS AND CLEARANCES

All clearances given at room temperature of 70° F (21° C)

All dimensions in inches unless otherwise specified (metric equivalents in parentheses where applicable).

	<u>Minimum</u>	<u>Maximum</u>
Tappets		
Intake	0.006 (0.152 mm)	0.008 (0.203 mm)
Exhaust	0.015 (0.381 mm)	0.017 (0.432 mm)
Valve Stem in Guide		
Intake	0.0010 (0.025 mm)	0.0025 (0.064 mm)
Exhaust	0.0025 (0.064 mm)	0.0040 (0.102 mm)
Valve Seat Interference Width	1/32 (0.792 mm)	3/64 (1.189 mm)
Valve Face Angle		44°
Valve Seat Angle		45°
Valve Interference Angle		1°
Crankshaft Main Bearing	0.0025 (0.064 mm)	0.0038 (0.096 mm)
Crankshaft End Play	0.006 (0.152 mm)	0.012 (0.305 mm)
Camshaft Bearing	0.0015 (0.038 mm)	0.0030 (0.076 mm)
Camshaft End Play	0.003 (0.076 mm)	
Rod Bearing	0.0005 (0.013 mm)	0.0023 (0.058 mm)
Connecting Rod End Play	0.002 (0.051 mm)	0.016 (0.406 mm)
Timing Gear Backlash	0.002 (0.051 mm)	0.003 (0.076 mm)
Oil Pump Gear Backlash	0.002 (0.051 mm)	0.005 (0.127 mm)
Piston to Cylinder, Conformatic Type (measured below oil-controlling ring — 90° from pin) Clearance	0.0025 (0.0635 mm)	0.0045 (0.1143 mm)
Piston Pin in Piston		Thumb Push Fit
Piston Pin in Rod	0.0002 (0.005 mm)	0.0007 (0.018 mm)
Piston Ring Gap in Cylinder	0.010 (0.254 mm)	0.023 (0.584 mm)
Crankshaft Main Bearing Journal — Standard Size	1.9992 (5.0779 mm)	2.0000 (5.0800 mm)
Crankshaft Rod Bearing Journal — Standard Size	1.6252 (4.1280 mm)	1.6260 (4.1300 mm)
Cylinder Bore — Standard Size — Honed	3.249 (8.252 mm)	3.250 (8.2550 mm)

Tune-Up Specifications

Breaker Point Gap (full separation)	0.020 (0.508 mm)
Spark Plug Gap	0.025 (0.635 mm)
Ignition Timing	19° BTC
Carburetor Float Clearance (between float bowl gasket and float)	5/16 (7.9 mm)

ASSEMBLY TORQUES

TORQUES

Assembly torques as given here require the use of a torque wrench. These assembly torques will assure proper tightness without danger of stripping the threads. If a torque wrench is not available, you will have to estimate the degree of tightness necessary for the stud, nut or screw being installed and tighten accordingly. Be careful not to strip the threads. Check all studs, nuts and screws often with the engine cold. Tighten as needed to prevent them from working loose.

TORQUE SPECIFICATIONS	Ft.-Lb.	kg/m
Connecting Rod Bolt	27-29	3.73-4.01
Oil Pump	7-9	0.97-1.24
Oil Base Mounting Screws	43-48	5.95-6.64
Rear Bearing Plate	20-25	2.77-3.46
Gear Case Cover	10-13	1.38-1.80
Starter Mounting Bracket to Oil Base Screws	43-48	5.95-6.64
Other 5/16" Cylinder Block Nuts	10-12	1.38-1.66
Flywheel Capscrew	35-40	4.84-5.53
Cylinder Head Nuts	29-31	4.01-4.29
Valve Cover Capscrews ..	4-8	0.55-1.11
Manifold	15-20	2.07-2.77
Fuel Pump Mounting Screws	5-6	0.69-0.83
Carburetor Mounting Stud Nuts	8-12	1.11-1.66

TROUBLESHOOTING

TROUBLE															CAUSE								
Backfire at Carburetor	Bearing Wear	Black Exhaust	Blue Exhaust	Burned Valves	Connecting Rods	Cylinder Rod Wear	Engine Slowly	Engine Wear	Failure to Start	Governor Stops	Governor to Start	High Oil Pressure	Low Oil Pressure	Loss of Coolant	Mechanical Knocks	Misfiring	Overheating (Water Cooled)	Overheating (Air Cooled)	Piston Wear	Poor Compression	Ring Wear	Sticking Valves	
STARTING SYSTEM																							
																							Loose or Corroded Battery Connection
																							Low or Discharged Battery
																							Faulty Starter
																							Faulty Start Solenoid
IGNITION SYSTEM																							
																							Ignition Timing Wrong
																							Wrong Spark Plug Gap
																							Worn Points or Improper Gap Setting
																							Bad Ignition Coil or Condenser
																							Faulty Spark Plug Wires
FUEL SYSTEM																							
																							Out of Fuel - Check
																							Lean Fuel Mixture - Readjust
																							Rich Fuel Mixture or Choke Stuck
																							Engine Flooded
																							Poor Quality Fuel
																							Dirty Carburetor
																							Dirty Air Cleaner
																							Dirty Fuel Filter
																							Defective Fuel Pump
INTERNAL ENGINE																							
																							Wrong Valve Clearance
																							Broken Valve Spring
																							Valve or Valve Seal Leaking
																							Piston Rings Worn or Broken
																							Wrong Bearing Clearance
COOLING SYSTEM (AIR COOLED)																							
																							Poor Air Circulation
																							Dirty or Oily Cooling Fins
																							Blown Head Gasket
COOLING SYSTEM (WATER COOLED)																							
																							Insufficient Coolant
																							Faulty Thermostat
																							Worn Water Pump or Pump Seal
																							Water Passages Restricted
																							Defective Gaskets
																							Blown Head Gasket
LUBRICATION SYSTEM																							
																							Defective Oil Gauge
																							Relief Valve Stuck
																							Faulty Oil Pump
																							Dirty Oil or Filter
																							Oil Too Light or Diluted
																							Oil Level Low
																							Oil Too Heavy
																							Dirty Crankcase Breather Valve
THROTTLE AND GOVERNOR																							
																							Linkage Out of Adjustment
																							Linkage Worn or Disconnected
																							Governor Spring Sensitivity Too Great
																							Linkage Binding

OPERATION

BEFORE STARTING

Crankcase Oil

Be sure the crankcase has been filled with oil to the full mark on the oil level indicator. Refer to the *PERIODIC MAINTENANCE* section for the recommended oil changes and complete lubricating oil recommendations.

Recommended Fuel

The engine will perform most satisfactory on non-leaded or regular-grade gasoline. However, nonleaded gasoline is better for the engine. If a situation arises when you must use the tractor and these fuels are not available, premium or highly-leaded gasoline will work in the engine.

Before switching to a nonleaded gasoline from leaded gasoline, take this precaution. Remove the cylinder heads and remove all the lead deposits from the engine.

CAUTION If lead deposits are not removed from the engine before switching from leaded to non-leaded gasoline, preignition can occur and cause engine damage.

STARTING

Refer to tractor manual for location, setting and operation of electric start, choke and throttle controls.

APPLYING LOAD

If practical, allow the engine to warm up before applying heavy loads.

CAUTION Continuous overloading can cause engine heating and eventual engine damage.

Break-In Procedure

Controlled break-in with the proper oil and a conscientiously applied maintenance program will help to assure satisfactory service. While the engine can be loaded to the full nameplate horsepower rating during initial operation, apply half load the first few hours of operation with intermittent periods of full load.

During break-in, check oil level often. Add oil if the level is at low on the dipstick. Never overfill. This may cause oil to foam and enter the breather system.

Drain the initial oil fill after five hours of operation while the engine is still hot. See the *PERIODIC MAINTENANCE* section for oil recommendations.

WARNING

Do NOT check oil while the generating set is operating. Hot oil could cause burns by blowing out of oil fill tube due to crankcase pressure.

STOPPING

Refer to tractor manual for location and operation of "Stop" control.

HIGH OPERATING TEMPERATURE CONDITIONS

1. See that nothing obstructs airflow to and from the engine.
2. Keep cooling fins clean. Air housing should be properly installed and undamaged.
3. Keep ignition timing properly adjusted.

LOW OPERATING TEMPERATURE CONDITIONS

1. Use correct SAE oil for temperature conditions. Change oil only when engine is warm. If an unexpected temperature drop causes an emergency, move the tractor to a warm location.
2. Use fresh gasoline. Protect against moisture condensation. Below 0°F (-18°C), adjust carburetor main jet for a slightly richer fuel mixture.
3. Keep ignition system clean, properly adjusted and batteries in a well charged condition.
4. Partially restrict cool airflow, but use care to avoid overheating.

EXTREMELY DUSTY AND DIRTY CONDITIONS

1. Keep unit clean. Keep cooling surfaces clean.
2. Service air cleaner as frequently as necessary.
3. Change crankcase oil every 20 operating hours.
4. Keep oil and gasoline in dust-tight containers.
5. Keep governor linkage clean.

HIGH ALTITUDE OPERATION

For operation at altitudes of 2500 feet (762 meters) above sea level, close carburetor main jet adjustment slightly to maintain proper air-to-fuel ratio (refer to the "Fuel System" section). Maximum power will be reduced approximately four percent for each 1000 feet (305 meters) above sea level after the first 1000 feet (305 meters).

OUT-OF-SERVICE PROTECTION

Protect an engine which is to be out-of-service for more than 30 days as follows:

1. Run engine until thoroughly warm.
2. Turn off fuel supply and run until the engine stops.
3. Drain oil from oil base while still warm. Refill and attach a warning tag stating oil viscosity used.
4. Remove each spark plug. Pour 1 ounce (two tablespoons) of rust inhibitor oil (or SAE number 50 oil) into each cylinder. Crank engine slowly (by hand) several times. Install spark plugs.
5. Service air cleaner.
6. Plug exhaust outlet to prevent entrance of moisture, dirt, bugs, etc.
7. Provide a suitable cover for the entire unit.
8. If battery is used, disconnect and follow standard battery storage procedure.

PERIODIC MAINTENANCE

PERIODIC MAINTENANCE SCHEDULE

Regularly scheduled maintenance is the key to lower operating costs and longer service life for the unit. Use the following schedule as a guide. However, actual operating conditions under which a unit is run should be the determining factor in establishing a maintenance schedule. When operating in very dusty or dirty conditions, reduce some service periods.

Check the condition of the crankcase oil, the filters, etc. frequently until the proper service time periods can be established.

For any abnormalities in operation, unusual noises from engine or accessories, loss of power, overheating, etc., contact your Onan dealer.

SERVICE THESE ITEMS	AFTER INDICATED OPERATING HOURS					
	8	40	80	100	200	400
Inspect Engine Generally	x					
Check Oil Level	x					
Clean Governor Linkage		x1				
Service Air Cleaner		x1				
Change Crankcase Oil		x1				
Replace Oil Filter			x			
Replace Spark Plugs				x		
Clean Breather Valve					x	
Check Breaker Points					x	
Check Battery Electrolyte Level					x	
Clean Fuel System					x	
Replace Air Cleaner Element					x1	
Remove Carbon & Lead Deposits						x
Check Valve Clearance						x

x1 - Perform more often in extremely dusty conditions.

NOTE: If tractor is out of service for more than 30 days (between seasons, for example), see "Out-of-Service Protection" in the OPERATION section.

WARNING All exhaust system connections **MUST** be checked regularly for any leaks and tightened as necessary. Do **NOT** terminate exhaust pipe under tractor.

CRANKCASE OIL

When changing oil, fill the crankcase to the FULL mark (Figure 1) with an SE (American Petroleum Institute designation) oil of the viscosity specified on the nameplate. If SE oil is not available, SD or SD/CC oil may be used.

Oil consumption may be higher with a multigrade oil than with a single grade oil if both oils have comparable viscosities at 210° F (99° C). Therefore, single grade oils are generally more desirable, unless anticipating a wide range of temperatures. Use the proper grade oil for the expected conditions.

Check oil level every 8 operating hours. Change oil every 40 operating hours under normal operating conditions. When operating in extremely dusty or dirty conditions, change oil every 20 operating hours.

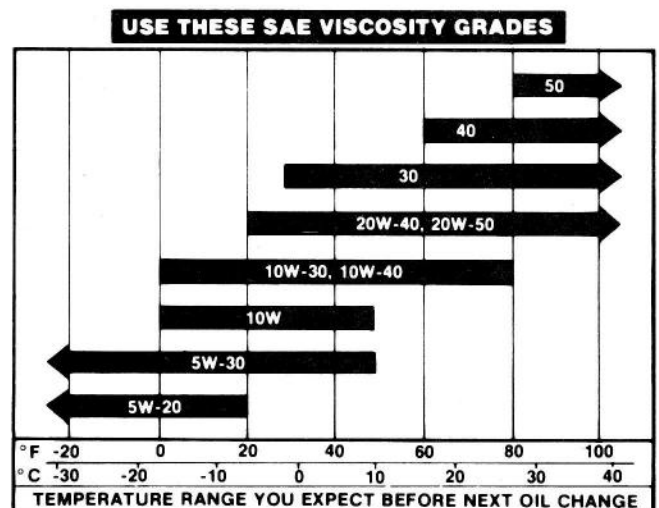

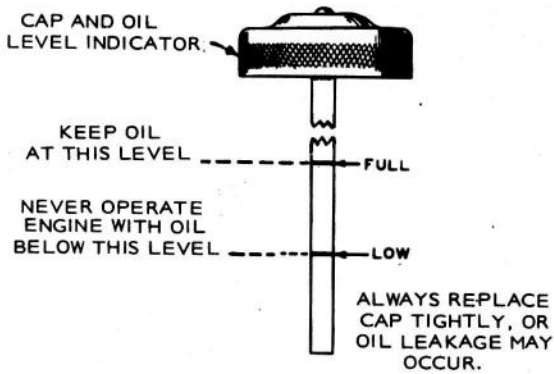

FIGURE 1. OIL LEVEL INDICATOR

Change the crankcase oil filter every other oil change (80 operating hours). Remove the filter by turning counterclockwise, using a filter wrench. Add the air seal over the filter to prevent air loss around the housing (Figure 2). Coat rubber gasket on filter with film of oil before installing. Install the filter finger tight plus 1/4 to 1/2 turn. If oil becomes so dirty that the markings on the oil level indicator cannot be seen, change the filter and shorten the filter service period.

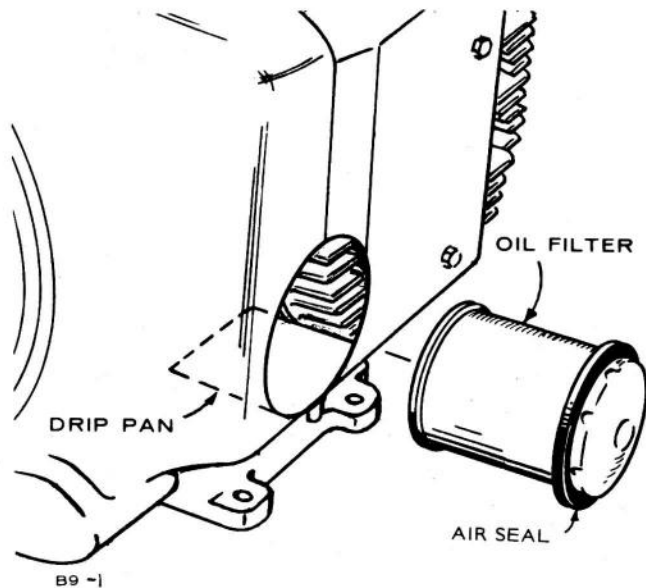

FIGURE 2. OIL FILTER AND AIR SEAL

AIR FILTER

The CCKA engine is equipped with a paper cartridge, automotive type air filter (Figure 3). Under normal usage, change the filter every 200 operating hours.

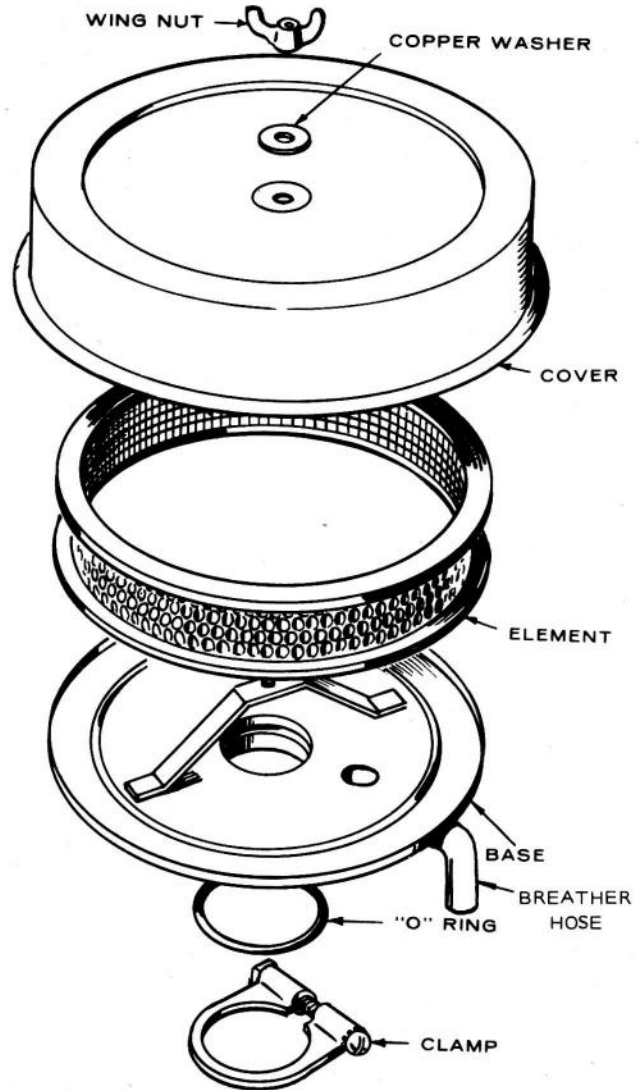

FIGURE 3. AIR CLEANER ASSEMBLY

Extremely dusty conditions may require a change every 50 operating hours. Inspect the filter more frequently if the engine appears to be losing power or idles roughly.

To service the air filter, remove the wing nut and washer at the top. If the filter element is dirty, clean by tapping gently on a flat surface. When cleaning, do not dent the sealing surfaces.

Clean the sealing surfaces, pan and cover before reassembly. Check to see that the pan is assembled firmly onto the carburetor air intake. The "O" ring in the pan neck should make a tight seal around the air intake. Tighten the clamp on the air intake. See Figure 3. Reassemble the air filter and replace the washer and wing nut; tighten the wing nut finger-tight only.

CRANKCASE BREATHER

Begin Spec J

Clean the crankcase breather cap, valve assembly and the breather tube baffle in a petroleum-base solvent every 200 operational hours. To remove breather cap and valve assembly, remove the breather hose clamp and breather tube clamp (Figure 4).

WARNING Use extreme care when cleaning with a petroleum-base cleanser due to fire hazard.

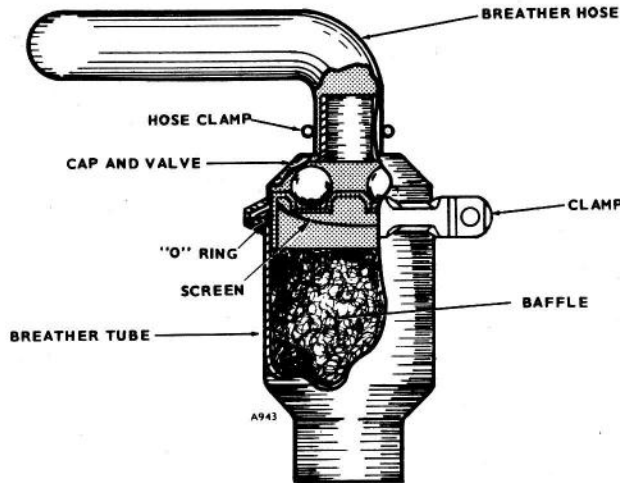

FIGURE 4. CRANKCASE BREATHER, BEGIN SPEC J

Spec G

Clean the crankcase breather every 200 operating hours (Figure 5). To clean the breather, lift off the rubber breather cap. Carefully pry the valve from cap. Otherwise press hard with both of your thumbs on top of cap and fingers below to release valve from rubber cap. Wash this fabric flapper type check valve in a petroleum-base solvent. Dry and reinstall, positioning perforated disc toward engine.

WARNING Use extreme care when cleaning with a petroleum-base cleanser due to fire hazard.

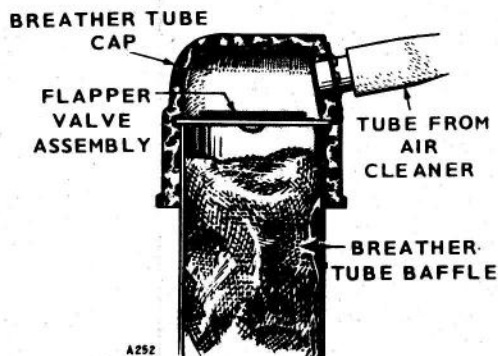

FIGURE 5. CRANKCASE BREATHER, SPEC G

GOVERNOR LINKAGE

The linkage must be able to move freely through its entire travel. Every 40 hours of operation, clean the joints and lubricate as shown in Figure 6. Also inspect the linkage for binding, excessive slack and wear.

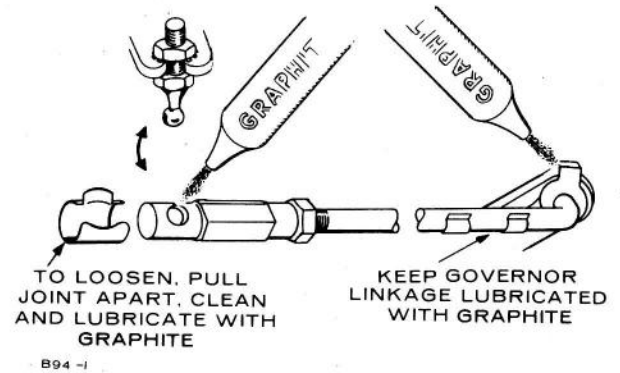

FIGURE 6. GOVERNOR LINKAGE

SPARK PLUGS

Each time the spark plugs are removed, inspect, clean and regap (Figure 7). If the plug looks discolored or has fouled, replace it.

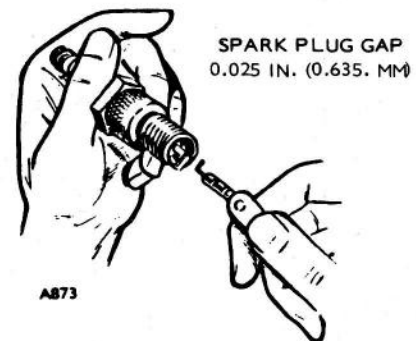

FIGURE 7. CHECKING SPARK PLUG GAP

ENGINE DISASSEMBLY

If engine disassembly is necessary, observe the following order (i.e. flywheel, gear cover . . .). As disassembly progresses, the order may be changed as will be self-evident. The engine assembly procedure is the reverse of disassembly. Any special assembly instructions for a particular group are included in the applicable section. When reassembling, check each section for these special assembly instructions or procedures.

FLYWHEEL

Removing the flywheel is a relatively simple process, but the following procedure must be followed to avoid damage to the gear case and possible injury to the operator.

1. Turn the flywheel mounting screw outward about two turns.

WARNING Do not remove the screw completely since it acts as a restrainer when the flywheel snaps loose.

2. Install a puller bar (Onan tool number 420-0100) on the flywheel as shown in Figure 8.

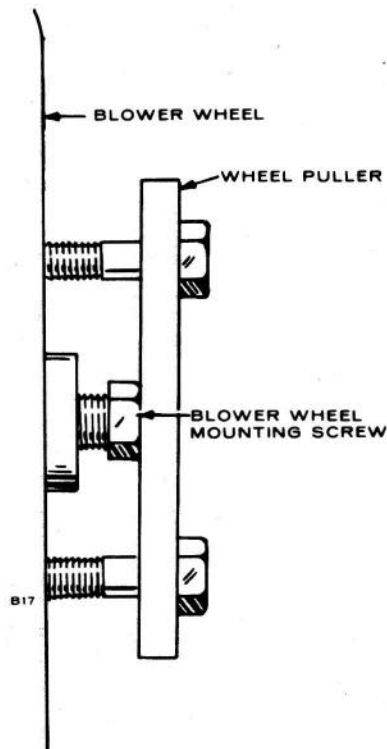

FIGURE 8. BLOWER WHEEL PULLER

3. Turn the puller bar bolts in alternately, until the wheel snaps loose on the shaft.

CAUTION Do not use a screwdriver or similar tool to pry behind the flywheel against the gear case cover. The gear case cover is die-cast material and will break if too much pressure is applied in this manner.

4. Unscrew the puller from the flywheel, remove the flywheel mounting screw and washer and pull the flywheel off the shaft. Take care not to drop the wheel. Always use a steel key for mounting the flywheel.

TRANSMISSION DRIVE GEARS

A standard gear puller is required to remove the drive gears from the crankshaft. If unusual resistance is encountered, remove the puller and heat the gears with a torch.

CAUTION Take care not to overheat and cause the temper to be drawn from the gears. Excessive heat can damage the rear oil seal.

WARNING Take care not to burn yourself with the torch or hot gears when removing or reinstalling.

Reinstall the puller and proceed as before until the gears come loose.

To reinstall the gears, heat the gears in oil at 400° F (205° C) and place them on the shaft with the shaft keys in place. Set a collar on the shaft, such as a pipe coupling; place a heavy washer over the end and turn the shaft screw in until the gears are properly seated. See Figure 9.

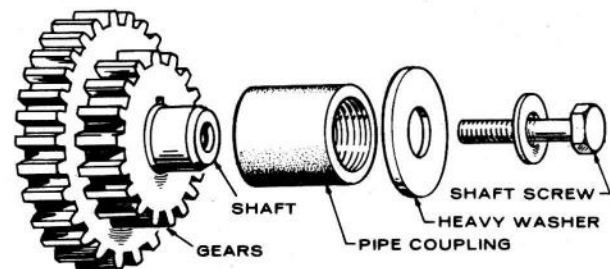

FIGURE 9. DRIVE GEAR INSTALLATION

GEAR COVER

After removing the flywheel key and mounting screws, tap the gear cover gently with a soft-faced hammer to loosen it.

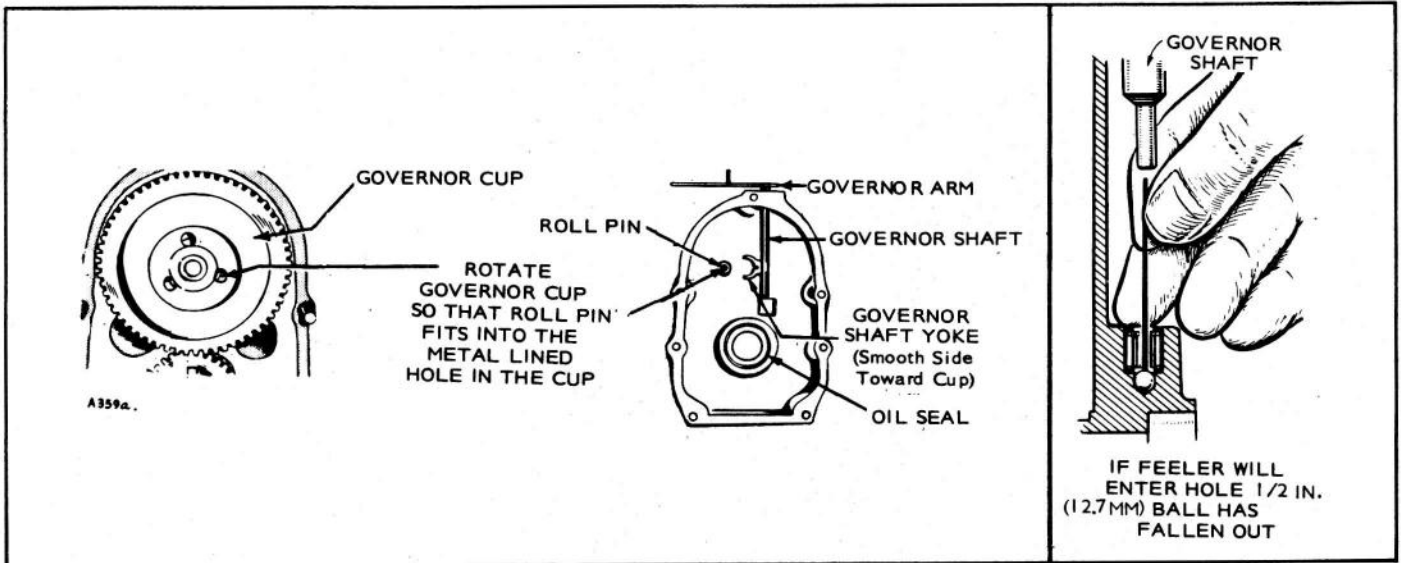

FIGURE 10. GEAR COVER ASSEMBLY

CAUTION When installing the gear cover, make sure that the pin in the gear cover engages the governor cup correctly (see following).

Turn the governor cup so that the metal lined hole is at the three o'clock position. The smooth side of the governor yoke must ride against the governor cup. Turn the governor arm and shaft clockwise as far as possible and hold in this position until the gear cover is installed flush against the crankcase.

CAUTION Be careful not to damage the gear cover oil seal. If damaged, it will have to be replaced.

Adjust the roll (stop) pin to protrude to a point $\frac{3}{4}$ inch (19.05 mm) from the cover mounting surface. See Figure 10.

GOVERNOR CUP

With the gear cover removed, the governor can be taken off after removing the snap ring from the camshaft center pin. Catch the flyballs while sliding the cup off. See Figure 11.

Replace any flyball that is grooved or has a flat spot. If the arms of the ball spacer are worn or otherwise damaged, replace the entire timing gear set. The governor cup must spin freely on the camshaft center pin without excessive looseness or wobble. If the race surface of the cup is grooved or rough, replace it with a new one.

When installing the governor cup, tilt the engine so the gear is up, put the flyballs in place and install the cup and snap ring on the center pin (Figure 11).

The camshaft center pin extends out $\frac{3}{4}$ inch (19.05 mm) from the end of the camshaft. This distance provides an in and out travel distance of $\frac{7}{32}$ inch (7.55 mm) for the governor cup, as illustrated. Hold

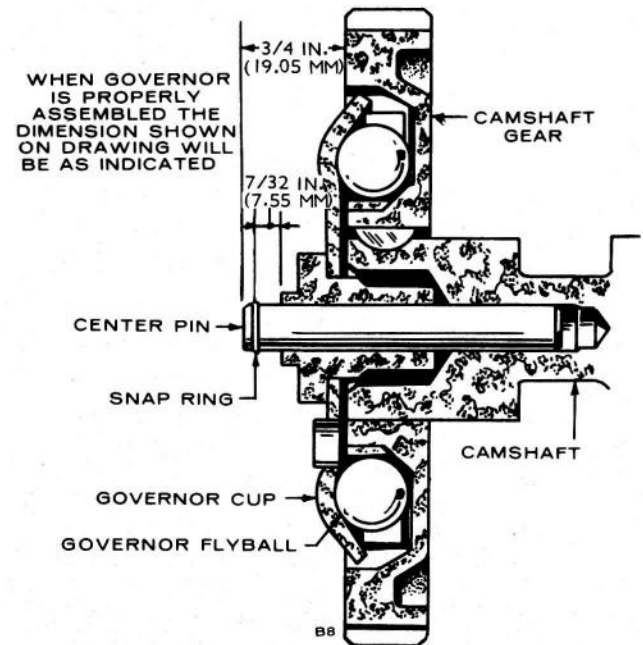

FIGURE 11. GOVERNOR CUP

the cup against the flyballs when measuring. If the distance is less (the engine may race, especially at no load), remove the center pin and press a new pin in only the required amount. Otherwise, grind off the hub of the cup as required. The camshaft center pin cannot be pulled outward nor removed without damage. If the center pin extends out too far, the cup will not hold the flyballs properly.

TIMING GEARS

If replacement of either the crankshaft gear or the camshaft gear becomes necessary, install both gears

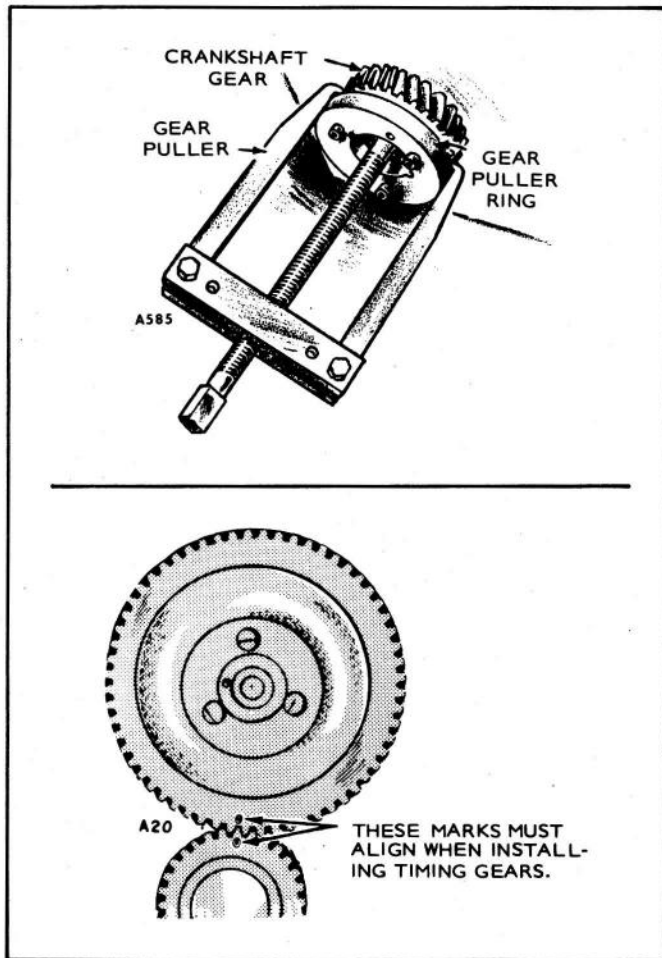

FIGURE 12. TIMING GEAR REMOVAL AND INSTALLATION

new, never one only. Use a gear pulling ring (Onan tool number 420-0248) to remove the crankshaft gear. Be sure to remove the snap ring first. See Figure 12.

The camshaft gear is pressed on and keyed to the camshaft. Remove the camshaft and gear as an assembly after first removing the crankshaft gear, lock ring and washer. Before removing the camshaft and gear assembly, remove the cylinder head and valve assemblies. Remove the operating plunger for the breaker points. Remove the fuel pump and tappets.

Press the camshaft out of the gear by use of a hollow tool or pipe which will fit over the camshaft center pin.

CAUTION Do not press on the center pin or otherwise damage it in any way. The governor ball spacer is a press fit to the camshaft gear.

When pressing a camshaft gear onto the camshaft, be sure the gear is started straight and that the key is properly in place. Install the governor cup assembly before installing the camshaft and gear in the engine.

Each timing gear is stamped with an O mark near the

edge. The gear teeth must mesh so that these marks coincide exactly when the gears are installed in the engine (Figure 12). Be sure, when installing the camshaft gear and shaft assembly, that the thrust washer is properly in place behind the camshaft gear. Replace the camshaft retaining washer and lock ring to the crankshaft.

CYLINDER HEADS

Tighten the cylinder head in the order designated per Figure 13 to a torque of 5 foot-pounds (0.69 kg/m), then 10 foot-pounds (1.38 kg/m), etc., until all are torqued 29 to 31 foot-pounds (4.01 to 4.29 kg/m).

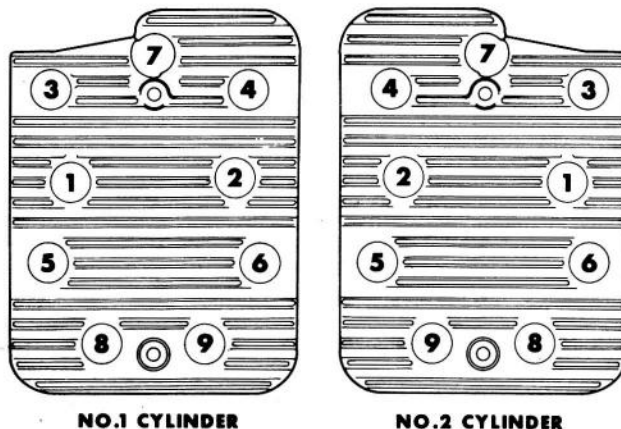

FIGURE 13. HEAD BOLT TIGHTENING SEQUENCE

VALVES

Properly seated valves are essential to good engine performance. The cylinder head is removable for valve servicing. Do not use a pry to loosen the cylinder head. Rap sharply on the edge with a soft-faced hammer, taking care not to break any cooling fins. A conventional type valve spring lifter may be used when removing the valve spring locks, which are of the split type. Clean all carbon deposits from the cylinder head, piston top, valves, guides, etc. If a valve face is burned or warped, or the stem worn, install a new valve.

Worn valve stem guides may be replaced from inside the valve chamber. See Figure 14. A seal is provided behind the intake valve guides only. The smaller diameter of the tapered valve guides must face toward the valve head.

Tappets are also replaceable from the valve chamber, after first removing the valve assemblies.

The valve face angle is 44°. The valve seat angle is 45°. This 1° interference angle results in a sharp seating surface between the valve and the top of the valve seat. The interference angle method of grinding valves minimizes face deposits and lengthens valve life (Figure 15).

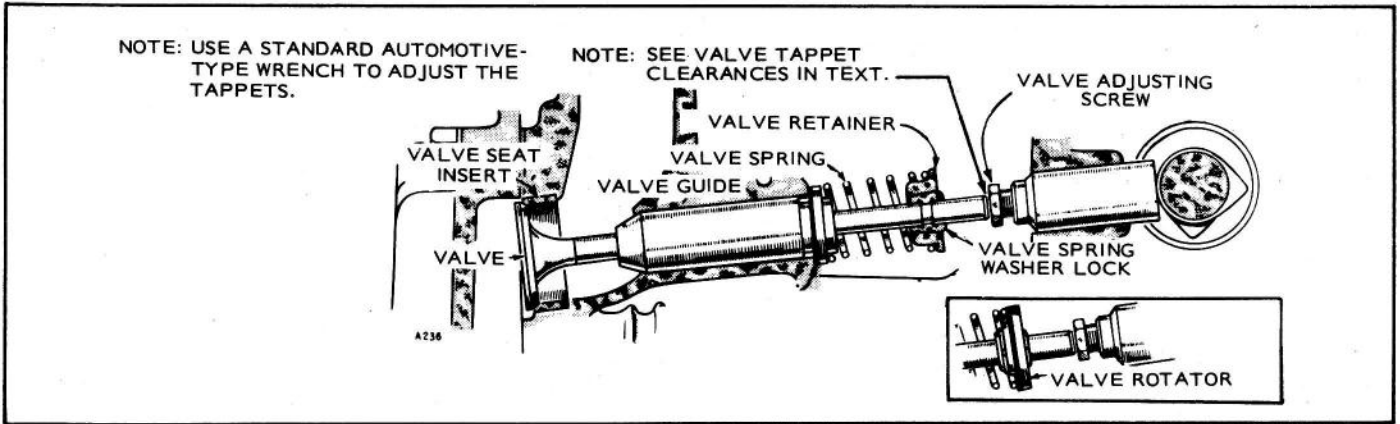

FIGURE 14. CCKA VALVE SYSTEM

CAUTION Do not hand lap the valves, if at all avoidable, since the sharp contact can be destroyed. This is especially important where stellite faced valves and seats are used.

Finish the valve faces in a machine to 44° . Grind the valve seats with a 45° stone. Width of the seat band should be $1/32$ to $3/64$ (0.792 to 1.189 mm) of an inch wide. Grind only enough to assure proper seating.

Remove all grinding compound from engine parts and place each valve in its proper location. Check each valve for a tight seat, using an air pressure type testing tool. If such a tool is not available, make pencil marks at intervals across the valve face and observe if

the marks rub off uniformly when the valve is rotated part of a turn against the seat.

Lightly oil the valve stems and reassemble all parts removed. Adjust the valve clearance (see *Tappet Adjustment*).

The positive type valve rotocoils serve to prolong valve life and decrease valve repairs. Check the rotocoils periodically by removing the cylinder heads and cranking the engine. When functioning properly, the valve is rotated a fraction of a turn each time it opens. If rotocoils are faulty, install new ones.

TAPPET ADJUSTMENT

The engine is equipped with adjustable tappets. To make a valve adjustment, remove the valve covers. Crank the engine over slowly by hand until the left hand intake valve, when facing the flywheel, opens and closes. Continue about $1/4$ turn until the correct timing marks align. This should place the left hand piston at the top of its compression stroke, the position it must be in to get proper valve adjustment for the left hand cylinder. Clearances are shown in *DIMENSIONS AND CLEARANCES* section. For each valve, the gauge should just pass between the valve stem and valve tappet (Figure 16).

To correct the valve clearance, turn the adjusting screw as needed to obtain the right clearance. The screw is self-locking.

To adjust the valves on the right hand cylinder, crank the engine over one complete revolution and again line up the correct timing marks. Then follow the adjustment given for the valves of the left hand cylinder.

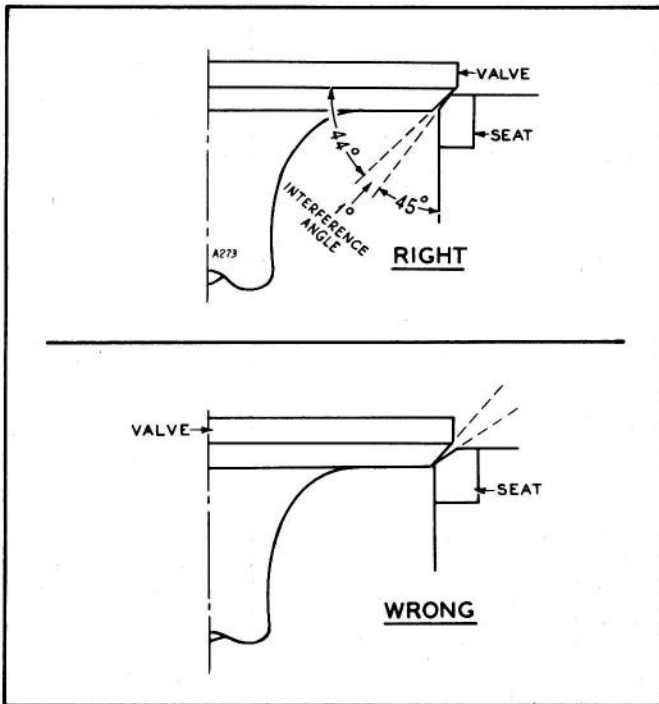

FIGURE 15. VALVE FACE AND SEAT ANGLES

**INTAKE AND EXHAUST VALVES
(SEE TABLE OF CLEARANCES)**

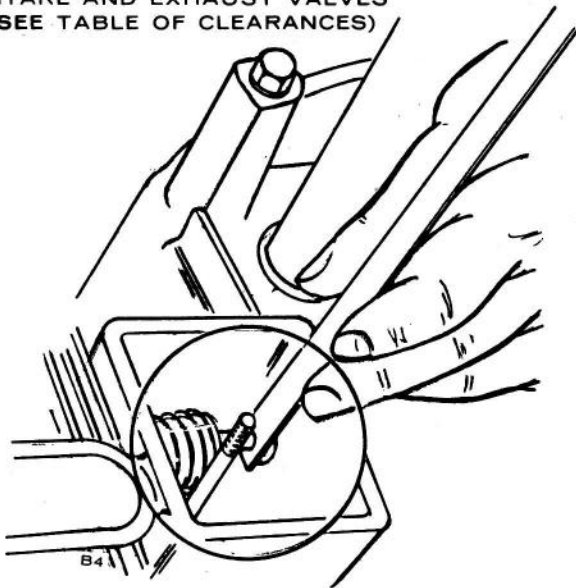

FIGURE 16. ADJUSTING TAPPETS

Keep the connecting rod bearing caps and bearings with their respective rods.

The pistons are fitted with two compression rings on top and one oil control ring on bottom with an expander. Remove these rings from the piston using a piston ring spreader.

Clean the piston ring grooves with a groove cleaner (Figure 18). Clean all passages with a non-caustic solvent. Clean the rod bore and the back of the connecting rod bearings thoroughly.

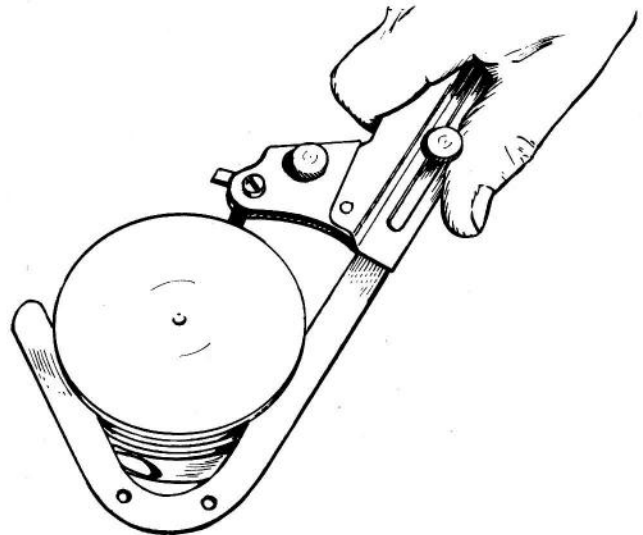

FIGURE 18. CLEANING RING GROOVES

PISTONS AND RINGS

Whenever there is a noticeable wear ridge at the top of each cylinder, remove the ridge with a ridge reamer before removing the pistons. If not, the rings can catch the ridge when pushing out the pistons and cause a ring land fracture (Figure 17).

To remove the piston and connecting rod assemblies, turn the crankshaft until a piston is at the bottom of the stroke. Remove the nuts from the connecting rod bolts. Lift the rod bearing cap from the rod, and push the rod and piston assembly out the top of the cylinder with the handle end of a hammer. Be careful not to scratch the crankpin or the cylinder wall when removing these parts.

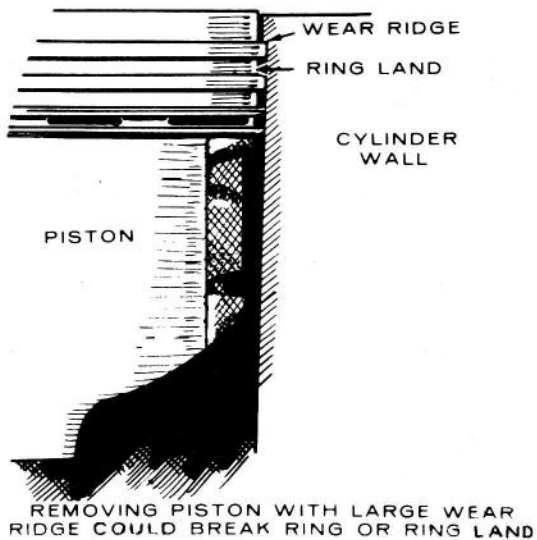

FIGURE 17. WEAR RIDGE ON CYLINDER WALL

Mark each piston to make sure the rod will be assembled on the piston from which it was removed. Remove the piston pin retainer from each side and push the pin out.

Inspect the pistons for fractures at the ring lands, skirts and pin bosses. Check for wear at the ring land using new rings and a feeler gauge as shown in Figure 19. See *DIMENSIONS AND CLEARANCES* section for proper side clearance measurement and ring groove widths.

Improper width rings or excessive ring side clearance can result in ring breakage. New rings in worn ring grooves don't have good cylinder wall contact (Figure 20).

Replace pistons showing signs of bad scoring or burring, excessive skirt clearance, wavy or worn ring lands, fractures or damage from detonation. Replace piston pins showing fractures, scored bores or bores out of round more than 0.002 inch (0.051 mm).

Use a new piston pin to check the pin bushing in the

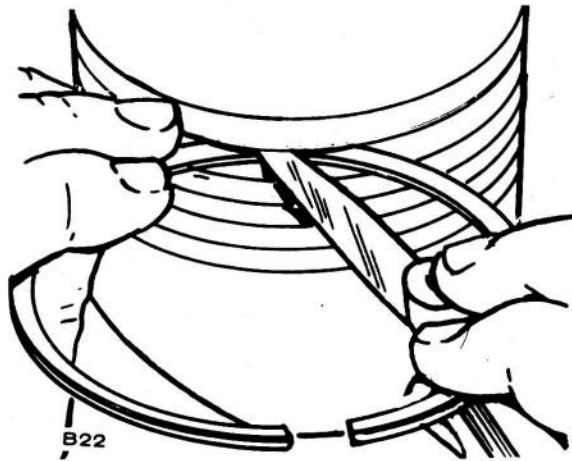

FIGURE 19. INSPECTING RING LANDS

connecting rod for wear. The clearance should be as shown in *DIMENSIONS AND CLEARANCES* section.

Before installing new rings on the piston, check the ring gap by placing each ring squarely in its cylinder at a position corresponding to the bottom of its travel (see Figure 21). The gap between the ends of the ring is given in *DIMENSIONS AND CLEARANCES* section. Rings which are slightly oversize can be filed as necessary to obtain the correct gap, but do not use rings which require too much filing. Standard size rings can be used on 0.005 inch (0.127 mm) oversize pistons. Other oversize rings must correspond with the oversize pistons. Rings of the tapered type are usually marked *top* on one side, or identified in some other manner. Install the ring with this mark toward the closed end of the piston.

Space each ring gap one third of the way around the piston from the preceding one, with no gap directly in line with the piston pin. The bottom piston ring groove

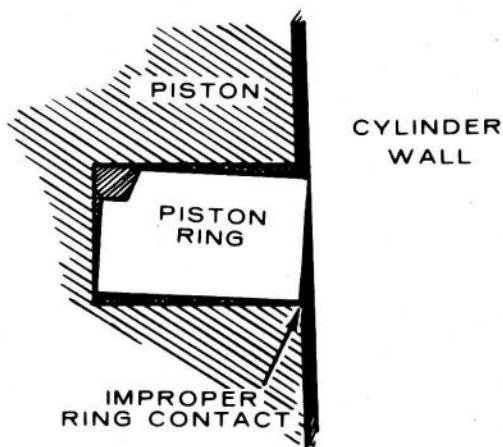

FIGURE 20. NEW RING IN WORN PISTON RING GROOVE

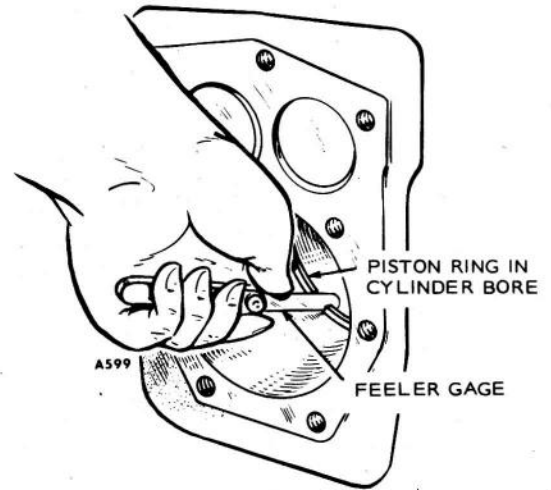

FIGURE 21. FITTING PISTON RINGS TO CYLINDER

should be fitted with an expander and an oil control ring and the two upper grooves fitted with compression rings. If a chrome faced ring is used, it will be in the top groove. The oil control ring is selected for best performance in regard to the correct unit pressure characteristics.

The piston is fitted with a full-floating type piston pin. The pin is kept in place by two lock rings in the piston, one at each side. Be sure these lock rings are properly in place before installing the piston and connecting rod in the engine. Refer to *DIMENSIONS AND CLEARANCES* section for the correct piston-to-cylinder clearance.

CONNECTING RODS

Service the connecting rods at the same time the pistons or rods are serviced. Remove the rods with the pistons. Replaceable bushings and bearings are used. See *PARTS CATALOG* section for available undersize and standard size bearings.

Proper clearance is obtained by replacing the pin bushing and the bearings. The rod bearings are precision size and require no reaming.

Install the connecting rods and caps with raised lines (witness marks) aligned and with the caps facing toward the oil base. The rod and cap numbered 2 fits on the crankshaft journal nearest the bearing plate. Coat the crankshaft journal bearing surfaces with oil before installing the rods. Crank the engine by hand to see that the rods are free. If necessary, rap the connecting rod cap screws sharply with a soft-faced hammer to set the rod square on the journal.

Checking Bearing Clearance With Plastigage

Make certain that all parts are marked or identified so that they are reinstalled in their original positions.

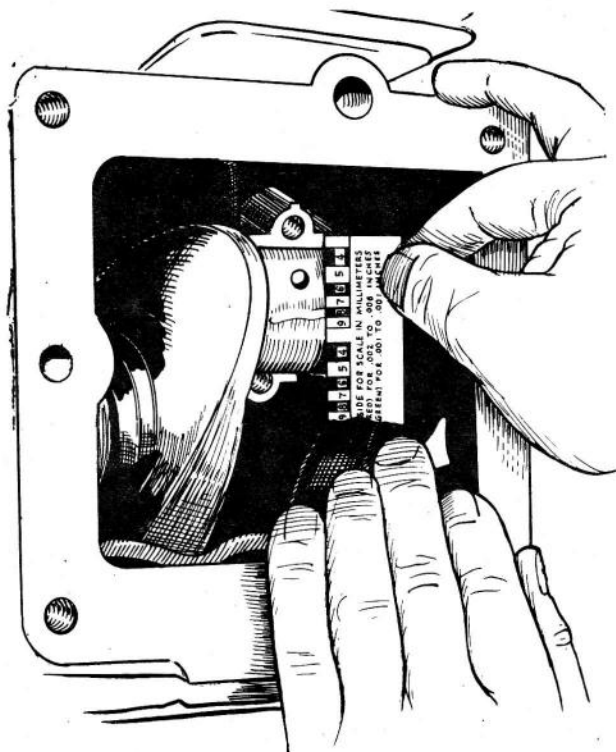

FIGURE 22. MEASURING BEARING CLEARANCE WITH PLASTIGAGE

Place a piece of correct size Plastigage in the bearing cap the full width of the bearing insert about 1/4 inch (6.35 mm) off center (Figure 22). Rotate the crank about 30° from bottom dead center and

reinstall the bearing cap. Tighten the bolts to the torque specified in the *ASSEMBLY TORQUES* section. Do not turn the crankshaft.

Remove the bearing cap. Leave the flattened Plastigage on the part to which it has adhered and compare the widest point with the graduations on the Plastigage envelope to determine bearing clearance.

CYLINDER BLOCK

Inspection

1. Make a thorough check for cracks. Minute cracks may be detected by coating the suspected area with a mixture of 25% kerosene and 75% light motor oil. Wipe the part dry and immediately apply a coating of zinc oxide (white lead) dissolved in wood alcohol. If cracks are present, the white coating will become discolored at the defective area.
2. Inspect the cylinder bore for scoring. Check the Welsh plugs for a tight, even fit and the fins for breakage.
3. Check the cylinder bore for taper, out of round and wear with a cylinder bore gauge, telescope gauge or inside micrometer (Figure 23). These measurements should be taken at four places — the top and bottom of piston ring travel.
4. Record measurements taken lengthwise at the top and bottom of the piston travel as follows:
 - a. Lengthwise of the block, measure and record as "A" the diameter of the cylinder at the top of the cylinder where the greatest ring wear occurs.

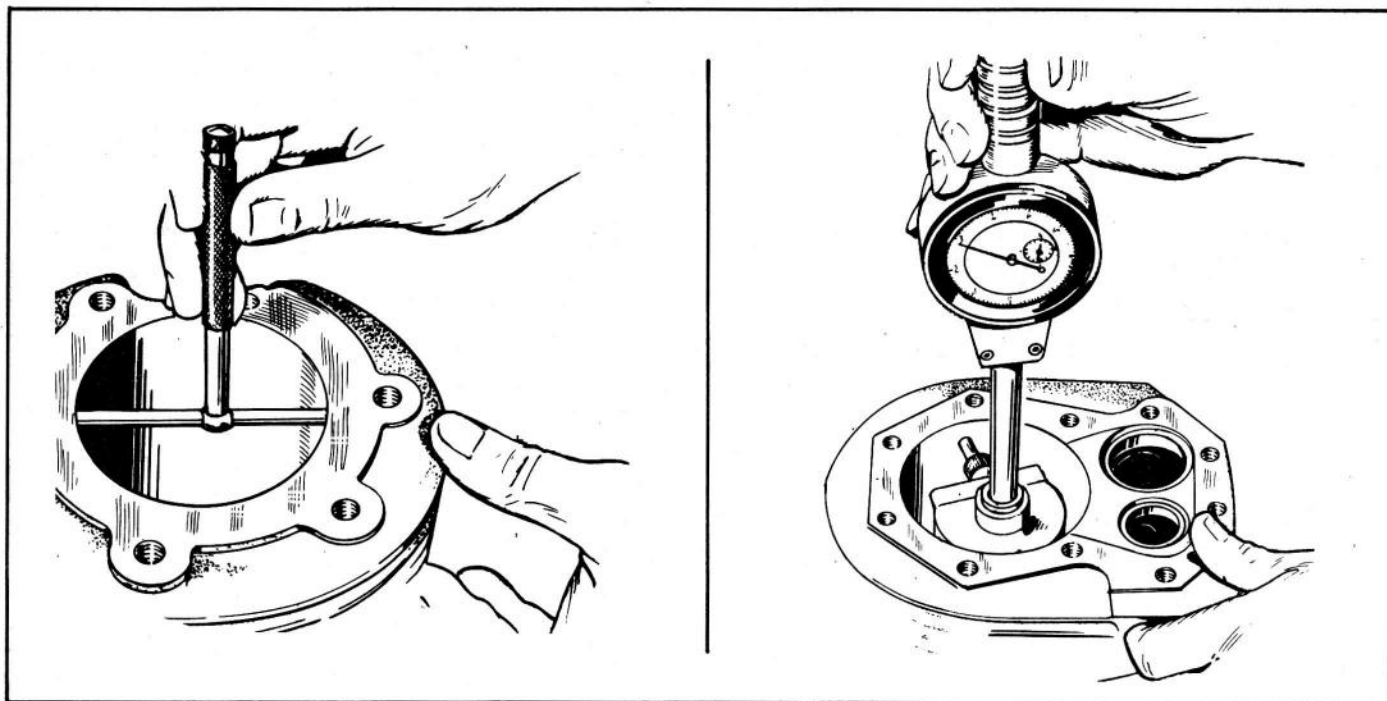

FIGURE 23. METHODS OF CYLINDER INSPECTION

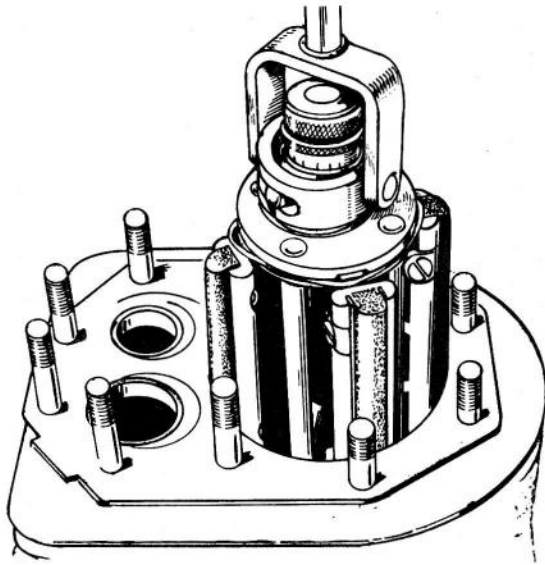

FIGURE 24. HONING CYLINDER

- b. Also, lengthwise of the block, measure and record as "B" the cylinder diameter at the piston skirt travel.
- c. Crosswise of the block, measure and record as "C" the diameter of the top of the cylinder at the greatest point of wear.
- d. Measure and record as "D" the diameter at the bottom of the cylinder bore and crosswise of the block.
- e. Reading "A" compared to "B" and reading "C" compared to reading "D" indicates cylinder taper.
- f. If cylinder taper exceeds 0.005 inch (0.127 mm), rebore and hone to accommodate the next oversize piston. Reading "A" compared to reading "C" and reading "B" compared to reading "D" indicates whether or not the cylinder is out of round. If the out of round exceeds 0.002 inch (0.051 mm), the cylinders must be rebored and honed for the next oversize piston. A reboring machine is used when going to oversize pistons. The following repair data covers honing to oversize by use of a hone.

Repair

1. A hone can be used to rebore a cylinder (Figure 24). Remove stock to 0.002 inch (0.051 mm), undersize of finish bore with coarse hone (100 grit), then complete honing with finish hones (300 grit).
2. Anchor the block solidly for either vertical or horizontal honing. Use either a drill press or heavy-duty drill which operates at approximately 250 to 450 rpm.
3. Lower the hone into the cylinder until it protrudes 1/2 to 3/4 inch (12.7 to 19.0 mm) past the end of the cylinder. Rotate the adjusting nut until the

stones come in contact with the cylinder wall at the narrowest point.

4. Turn the hone by hand. Loosen the adjusting nut until the hone can be turned.
5. Connect drill to hone and start drill. Move the hone up and down in the cylinder approximately 40 cycles per minute. Usually the bottom of the cylinder must be worked out first because it is smaller. Then when the cylinder takes a uniform diameter, move the hone up and down all the way through the bore. Follow the hone manufacturer's recommendations for wet or dry honing and oiling the hone.
6. Check the diameter of the cylinder regularly during honing. A dial bore gauge is the easiest method but a telescoping gauge can be used. Check the size at six places in the bore; measure twice at the top, middle and bottom at 90° angles.
7. When the cylinder is approximately 0.002 inch (0.051 mm) within the desired bore, change to fine stones and finish the bore. The finish should not be smooth but as shown in Figure 25. The crosshatch formed by the scratching of the stones should form an angle of 23°. This can be achieved by moving the hone up and down in the cylinder about 40 cycles per minute.
8. Clean the cylinder block thoroughly with soap, water and clean rags. A clean white rag should not be soiled on the wall after cleaning is complete. Do not use a solvent or gasoline since they wash the oil from the walls but leave the metal particles.
9. Dry the crankcase and coat it with oil.

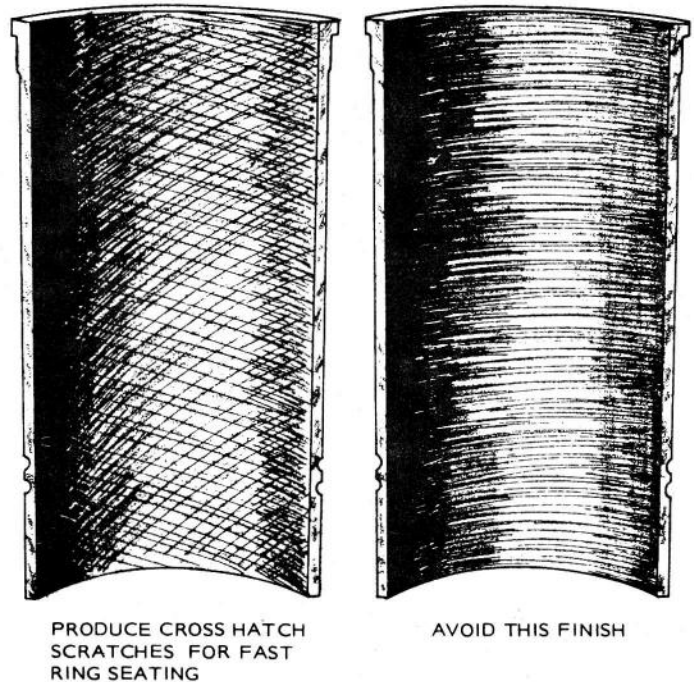

FIGURE 25. HONE FINISH

CRANKSHAFT

Inspect the bearing journals. If they are scored and cannot be smoothed out by dressing down, the bearing journals should be refinished to use nearest available undersize bearings or a new crankshaft should be installed. If a worn main bearing journal cannot be fitted with an available precision type undersize bearing, then refinish it to the next undersize. If a worn rod journal cannot be fitted by installing new bearing inserts, then refinish it to take the corresponding undersize bearing insert available.

Whenever making major repairs on the engine, always inspect the drilled passages of the crankshaft. Clean them to remove any foreign material and to assure proper lubrication of the connecting rods.

BEARINGS

Removal of the camshaft or crankshaft bearings requires complete disassembly of the engine. Use a press or a suitable drive plug to remove the bearings. Support the casting to avoid distortion and avoid damaging the bearing bore during removal and installation. Use oil on the bearings to reduce friction when installing and again lubricate with oil after installing (see Figure 26). Use Onan combination bearing driver 420-0324 to install the camshaft bearings.

Camshaft

Replacement camshaft bearings are precision type which do not require line reaming or line boring after installation. Coat the bearing with lubricating oil to reduce friction. Place the bearing on the crankcase over the bearing bore with the lubricating hole (front only) in proper position. Be sure to start the bearing straight. Press the front bearing in flush with the outside end of the bearing bore. Press the rear bearing in until past the ignition plunger hole.

Crankshaft

New crankshaft main bearings are precision type which *do not* require line reaming or line boring after installation. See *PARTS CATALOG* section for standard size and undersizes available.

Before putting in the main bearings, expand the bearing bore by placing the casting in hot water or in an oven heated to 200° F (93° C). If practical, cool the precision bearing to shrink it.

For putting in either the front or rear main bearing, using instructions following, always align the oil hole(s) in the bearing with the oil hole(s) in the bearing bore. The oil passage must be at least 1/2 open. The cold oiled precision bearing should require only light taps to position it. Install the bearing flush with the inside end of the bore. If the head of a lock pin is damaged, use side cutters or "Easy-Out" tool to remove pin. Then install a new lock pin. Apply oil to the thrust washers to hold in place when the

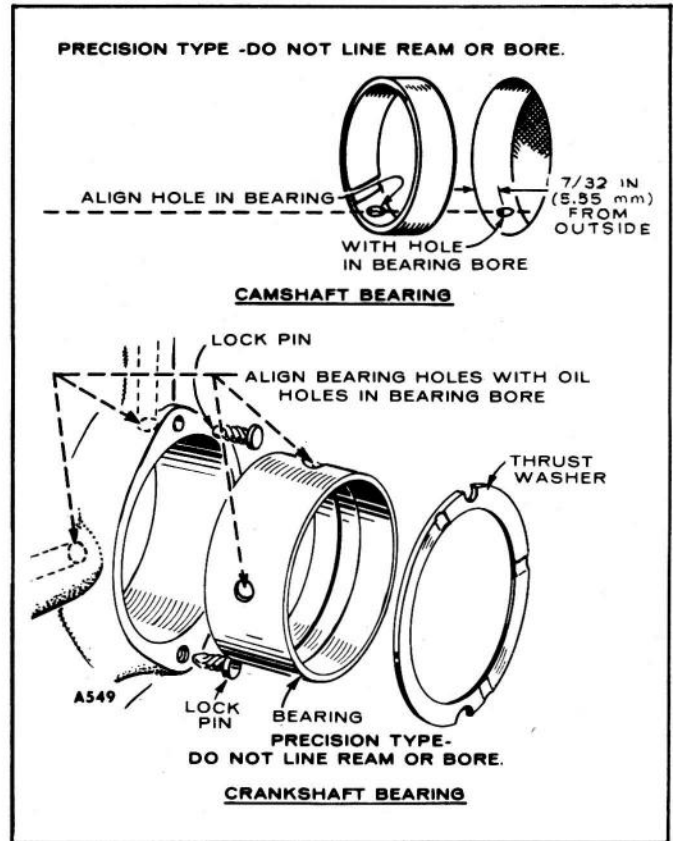

FIGURE 26. INSTALLATION OF CAM AND CRANKSHAFT BEARINGS

crankshaft is installed. The oil grooves in the thrust washer bearings must face the crankshaft. Be sure two notches fit over lock pins.

OIL SEALS

The bearing plate must be removed to replace its oil seal. Drive the oil seal out from the inside using Onan bearing plate driver 420-0181 and gear cover driver 420-0313.

Before installing the seals, fill the space between seals with a fibrous grease or stiff cup grease. This will improve sealing (see Figure 27).

When installing the gear cover oil seal, tap the seal inward until it is 1 inch (25.4 mm) from the mounting face of the cover. Install new style, thin open face seal, 1-7/64 inches (28.2 mm) from mounting face of cover.

When installing the bearing plate oil seal, tap the seal into the bearing plate bore to bottom against the shoulder in the plate bore. Use a seal expander, or place a piece of shim stock around the end of the crankshaft, when replacing the bearing plate to avoid damaging the seal. Remove the shim stock as soon as the plate is in place.

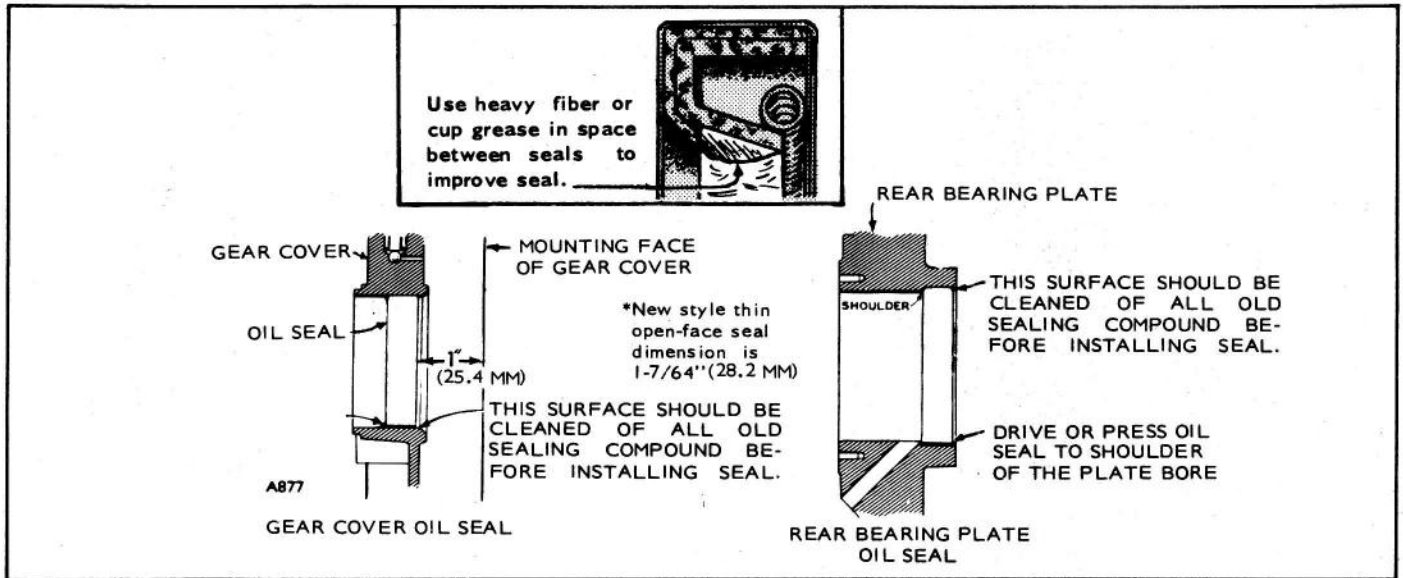

FIGURE 27. GEAR COVER AND REAR BEARING PLATE OIL SEALS

CRANKSHAFT ENDPLAY

After the rear bearing end plate has been tightened using the torque recommended in *ASSEMBLY TORQUES* section, check the crankshaft endplay as shown in Figure 28. If there is too much endplay (see *DIMENSIONS AND CLEARANCES* section for minimum and maximum endplay), remove the rear bearing endplate and replace the gasket with a thinner gasket from the gasket kit. For too little endplay, remove the rear bearing end plate and

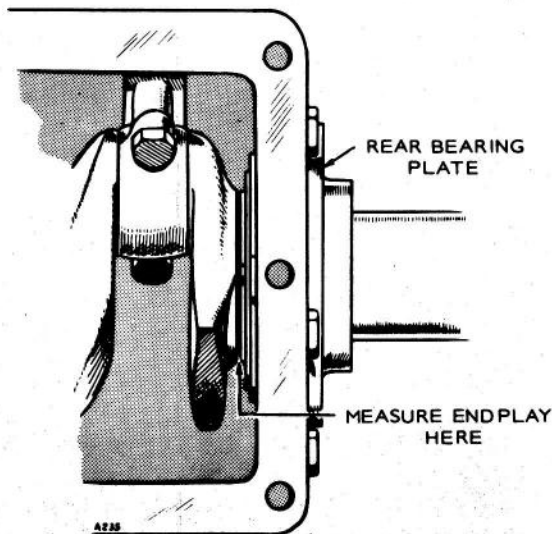

FIGURE 28. MEASURING CRANKSHAFT ENDPLAY

replace the gasket with a thicker one. Reinstall the end plate making sure the thrust washer notches line up with the lock pins. Torque and recheck endplay of the crankshaft.

OIL PUMP

Check the oil pump thoroughly for worn parts. Oil the pump to prime it before reinstalling (Figure 29). Except for gaskets, the component parts of the pump are not available individually. The suction cup is available separately. Install a new pump assembly, if required.

See the *OIL SYSTEM* section for description of the oil bypass relief valve and cleaning instruction if normal oil pressure (30 psi or higher) is in doubt.

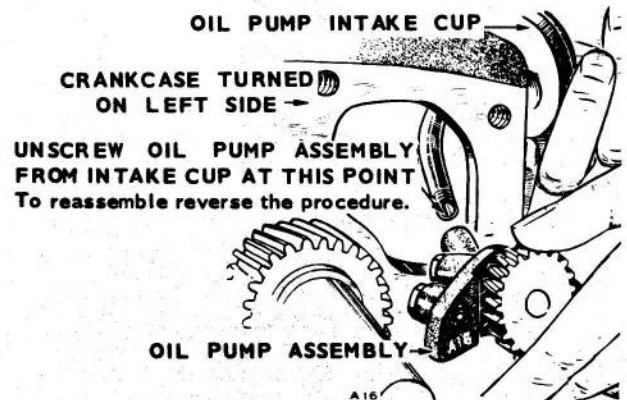

FIGURE 29. OIL PUMP

OIL SYSTEM

The CCKA engine has pressure lubrication to all working parts. The oil system includes:

- Oil intake cup
- Gear type oil pump
- Oil pressure gauge
- Oil passages to deliver oil throughout engine
- Oil filter

The oil pump is located on the front surface of the crankcase and is driven by the crank gear. The inlet pipe and screen assembly is attached directly to the pump body. A discharge passage in the cover of the pump registers with a drilled passage in the crankcase. Parallel passages distribute oil to the front main bearing, rear main bearing and pressure control bypass valve.

Circumferential grooves in the main bearings supply oil to the connecting rod bearings through drilled passages from each journal.

A drilled passage connects the front main bearing oil supply to the front camshaft bearing. The flyball governor is lubricated by a drilled passage in the front camshaft journal.

The oil overflow from the bypass valve furnishes lubrication to the camshaft drive gears.

OIL BYPASS VALVE

The bypass valve (located to the right and behind the gear cover) controls oil pressure by allowing excess oil to flow directly back to the crankcase. Normally the valve begins to open about 30 psi (2.11 kg/sq cm).

The valve is nonadjustable for all models begin Spec J and models CCKA-MS/2111G and CCKA-MS/2567G. Other Spec G models had an adjustable bypass valve (see "Bypass Valve Adjustment").

Normally the valve requires no maintenance. To determine if abnormal (high or low) oil pressure is caused by a sticky plunger, inspect as follows.

1. Remove capscrew or slotted stud and locknut located behind gear cover and under governor arm. Location of the capscrew is the same as shown for the slotted stud and locknut in Figure 30.

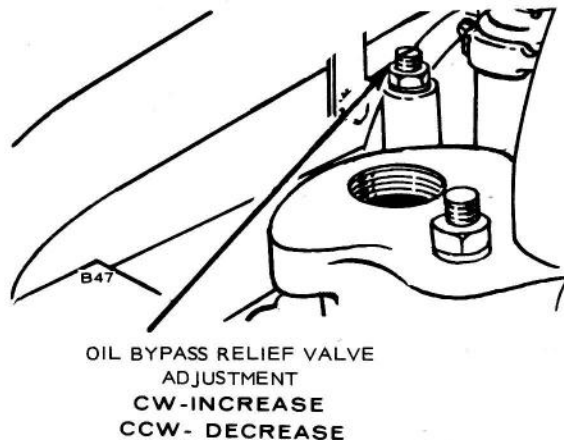

FIGURE 30. BYPASS VALVE ADJUSTMENT

2. Remove spring and plunger with a magnet tool. Clean plunger and spring with a suitable solvent and reinstall.

Bypass Valve Adjustment

This adjustment applies to all Spec G models except the CCKA-MS/2116G and CCKA-MS/2567G models. To increase oil pressure, loosen the locknut and turn the stud inward (Figure 30). To decrease oil pressure, loosen the locknut and turn the stud outward. Be sure to tighten the locknut securely after making an adjustment. The spring and plunger can be removed and cleaned.

Low oil pressure may indicate worn main or connecting rod bearings, improper clearance at these points, a weak or broken bypass spring, an improperly adjusted bypass or a defective gauge. Check the oil pressure gauge before making any other test; it may be defective.

LOW OIL PRESSURE SWITCH

All models except the CCKA-MS/1831G have a low oil pressure switch. It is generally used to operate a low oil pressure warning light for oil pressure lower than 8 to 10 pounds per square inch (0.56 to 0.70 kg/sq cm).

FUEL SYSTEM

GENERAL

Satisfactory engine performance is largely dependent upon correct fuel system adjustments. However, adjustments cannot fully compensate for low engine power due to wear, etc. If trouble develops, follow an orderly procedure to determine the cause before making any adjustment.

Adjusting the carburetor is means of obtaining the correct fuel-to-air mixture for smooth, efficient operation. Always adjust in two steps, first the load adjustment and then the idle adjustment.

CARBURETOR ADJUSTMENTS

Before adjusting the carburetor, be sure the ignition system is working properly and the governor is adjusted. Allow the engine to warm before starting carburetor adjustments.

If carburetor is completely out of adjustment so the engine will not start, open both adjustment screws counterclockwise 1 to 1-1/2 turns off their seats to permit starting. Do not force the needles against their seats. This can bend the needle.

1. Apply a full load to engine (if possible).
2. Turn the load adjustment screw clockwise (Figure 31) until engine speed drops. Then turn screw counterclockwise until engine speed returns to normal.

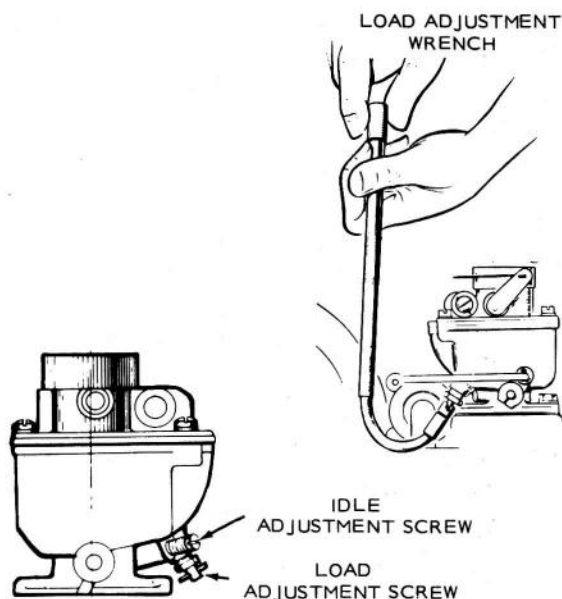

FIGURE 31. CARBURETOR ADJUSTMENTS

3. Remove load from the engine.
4. Turn idle adjustment screw counterclockwise until engine speed drops slightly. Then turn the screw clockwise until speed returns to normal.

Alternate Method (No load adjustment possible)

1. Start the engine and allow it to warm up.
2. Push in on the governor mechanism to slow the unit down to about 400 to 500 rpm.
3. Release the governor mechanism to allow the engine to accelerate. If the engine accelerates evenly and without a lag, the load screw setting is correct. If not, adjust the screw counterclockwise about 1/4 turn and again slow down the engine and release the mechanism. Continue until the engine accelerates evenly and without a time lag after releasing the governor.
4. Push in on the governor mechanism to slow the unit to 400 to 500 rpm. Set the idle screw for even operation so the engine is firing on both cylinders and running smoothly.

CARBURETOR DISASSEMBLY

1. Remove the choke linkage from the choke cable bracket and clip.
2. Remove the main carburetor body from the choke sleeve.
3. Remove the float pin and float. See Figure 32.
4. Lift out the fuel inlet valve and unscrew the valve seat.
5. Remove the load and idle adjustment screws.
6. Remove the throttle plate screws and the plate and pull out the throttle shaft.
7. Remove the choke plate screws and plate and pull out the choke shaft.

Cleaning and Repair

To clean the carburetor, soak all components thoroughly in a carburetor cleaner following the cleaner manufacturer's instructions. Be sure all carbon is cleaned from the carburetor bore, especially in the area of the throttle valve. Blow out the passages with compressed air. If possible, avoid using wire to clean out the passages. The float should fit freely on its pin without binding. Invert the carburetor body and measure the float level.

CARBURETOR ASSEMBLY

1. Install the throttle shaft and plate, using new screws and lockwashers. Install the bevel mated

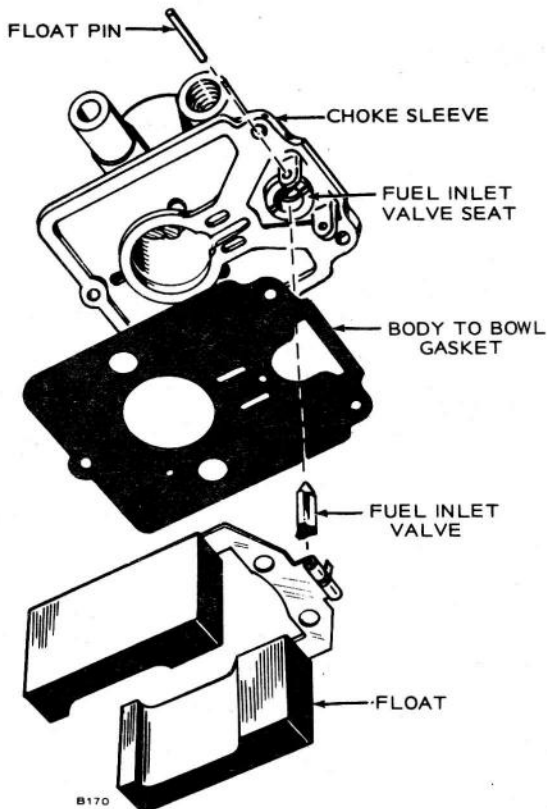

FIGURE 32. CARBURETOR DISASSEMBLY

to the carburetor body. On plates marked with the letter C, install with the mark on the side toward the idle port when viewed from the flange end of the carburetor. To center the plate, back off the top screw, close the throttle lever and seat the plate by tapping it with a small screwdriver. Then tighten the two screws.

2. Install the choke shaft and plate. Center the plate in the same manner as the throttle plate (Step 1). Use new screws and lockwashers.
3. Install the fuel inlet valve seat and valve.
4. Install the float and float pin. Center the pin so the float bowl does not ride against it.
5. Check the float level with the carburetor casting inverted. See Figure 33.
6. Install the carburetor body with the gasket aligned properly.
7. Install the fuel adjustment screws finger tight. Then back out 1 to 1-1/2 turns.
8. Reconnect the choke linkage.

FUEL PUMP

A diaphragm type fuel pump is used. If fuel does not reach the carburetor, check the fuel pump. To do this, disconnect the fuel line at the carburetor and, while cranking the engine slowly by hand, observe whether fuel comes through the line. Be sure there is fuel in the

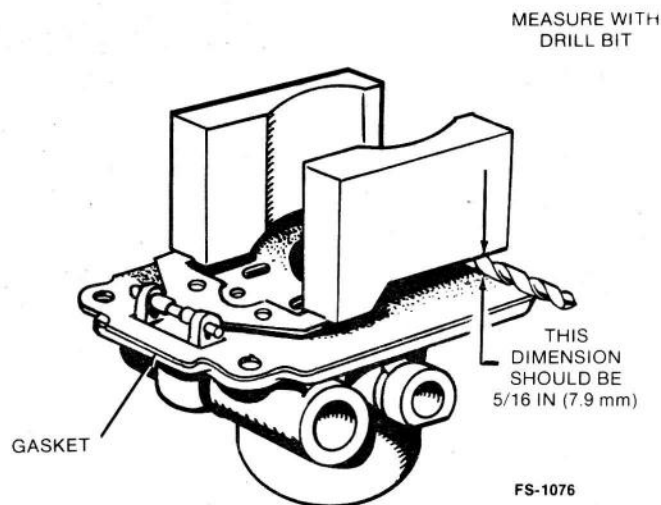
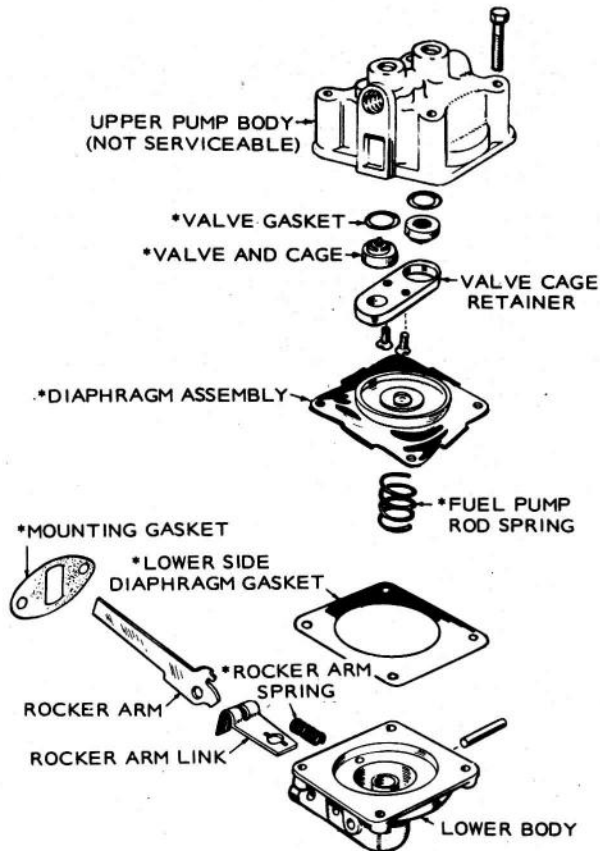

FIGURE 33. FLOAT LEVEL SETTING

tank. If the line is open and no fuel comes through, the pump is defective. Failure of the pump is usually due to a leaking diaphragm valve or valve gasket, a weak or broken spring, or wear in the drive linkage. Oil diluted with gasoline may indicate a faulty diaphragm. If the operator chooses to repair the pump rather than install a new one, the use of a complete repair kit is recommended.

Fuel Pump Reconditioning

1. Remove fuel lines and mounting screws holding pump to engine. See Figure 34.
2. Make an indicating mark with a file across a point at the union of the fuel pump bolt and cover. This mark will assure proper reassembly. Remove assembly screws and remove upper pump body.
3. Turn pump body over and remove valve plate screw and washer. Remove valve retainer, valves, valve springs and valve gasket, noting their position. Discard valve springs, valves and valve retainer gasket.
4. Clean pump body thoroughly with solvent and a fine wire brush.
5. Holding the pump cover with the diaphragm surface up, place the new valve gasket into the cavity. Assemble the valve spring and valves in the cavity. Reassemble the valve retainer. Lock in position by inserting and tightening fuel pump valve retainer screw.
6. Place pump body assembly in a clean place and rebuild the lower diaphragm section.
7. Holding mounting bracket, press down on the diaphragm to compress spring under it, then turn bracket 90 degrees to unhook diaphragm so it can be removed.
8. Clean mounting bracket with a solvent and a fine wire brush.



A320 Rev.

* - PARTS INCLUDED IN REPAIR KIT.

FIGURE 34. FUEL PUMP ASSEMBLY

9. Replace the diaphragm fuel pump rod spring, diaphragm gasket, stand new spring in casting, position diaphragm, compress spring and turn 90 degrees to reconnect diaphragm.
10. Hold bracket, then place the pump cover on it (make sure that indicating marks are in line) and insert the four screws. **DO NOT TIGHTEN.** With the hand on the mounting bracket only, push the pump lever to the limit of its travel and hold in this position while tightening the four screws.

CAUTION This is important to prevent stretching the diaphragm.

11. Mount the fuel pump on engine, using new mounting gaskets. Connect the fuel lines.

GOVERNOR ADJUSTMENT

Engine speed is governor-controlled and preset at the factory. Proper governor adjustment is one of the most important factors in maintaining the power and speed desired from the engine.

These engines are adapted for use where a wide range of speed settings is desired. Engine speed is controlled at any given point between minimum and maximum by simply shifting the throttle lever on the

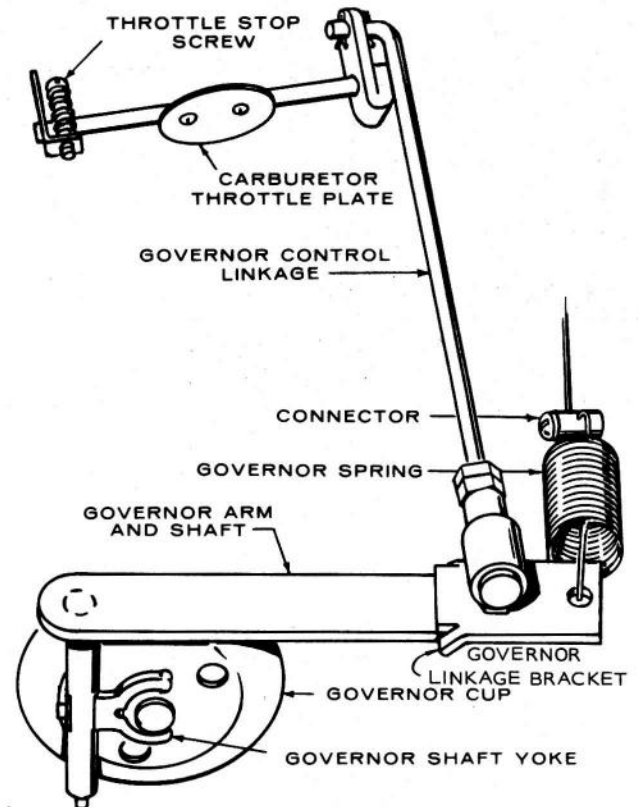

FIGURE 35. GOVERNOR LINKAGE

dash panel until the desired speed is reached.

The design of the variable speed governor gives an automatic decrease in sensitivity when the speed is increased and the result is good stability at all speeds.

Before making governor adjustment, run the engine about 15 minutes to reach normal operating temperature. If the engine is being run with the throttle wide open, either the governor is not properly adjusted or the engine is overloaded. After long usage, it is difficult to determine if the governor spring has become fatigued. Replace the spring if governor regulation is still erratic after making proper adjustments. See Figure 35.

A reliable instrument for checking engine speed is required for accurate governor adjustment. Engine speed can be checked with a tachometer.

Check the governor arm, linkage, throttle shaft, and lever for binding condition or excessive slack and wear at connecting points. A binding condition at any point will cause the governor to act slowly and regulation will be poor. Excessive looseness will cause a hunting condition and regulation will be erratic. Work the arm back and forth several times by hand while the engine is idle. If either of these conditions exists, find out where the trouble lies and adjust or replace parts as needed.

IGNITION AND BATTERY CHARGING

IGNITION SYSTEM

The engine is equipped with an automotive type battery ignition system. Both spark plugs fire simultaneously, thus the need for a distributor is eliminated. Spark advance is fixed at 19° BTC (before top center) which should be maintained for best performance. Ignition timing should be checked periodically, especially after breaker point replacement.

BREAKER POINTS

1. Remove the two screws and the cover on the breaker box.
2. Remove the two spark plugs so engine can be easily rotated by hand. If plugs have not been changed within the last 100 hours, replace them with new ones after setting the breaker points.
3. Remove the two mounting screws (A) and pull the points out of the box just far enough so screw (B) can be removed. See Figure 36. Replace points with a new set but do not completely tighten mounting screws (A).
4. Rotate the engine clockwise (facing flywheel) by hand until points are fully open. Turn screw (C) until point gap measures 0.020 inch (0.508 mm) with a flat thickness gauge.
5. Tighten mounting screws and recheck gap.
6. Proceed to *Ignition Timing*.

Each time new breaker points are installed, place a drop of oil on the point's pivot point (Figure 36).

IGNITION TIMING

Ignition Timing — Engine Running

Always check timing after replacing ignition points or if noticing poor engine performance. Proceed as follows:

1. To accurately check the ignition timing, use a timing light when engine is running. Connect the timing light according to its manufacturer's instructions. Either spark plug can be used as they fire simultaneously.
2. Place a white chalk or paint mark on the timing mark.
3. Start the engine and check the timing (19° BTC).
4. If timing needs adjustment, loosen the mounting screws on breaker box and move it left to advance or right to retard the timing.
5. Tighten the screws on the breaker box and recheck timing.
6. Replace breaker box cover and any other hardware removed.

Ignition Timing — Engine Not Running

1. Connect a continuity test lamp set across the ignition breaker points. Touch one test prod to the breaker box terminal to which the coil lead is connected and touch the other test prod to a good ground on the engine.
2. Turn crankshaft against rotation (counterclockwise) until the points close. Then slowly

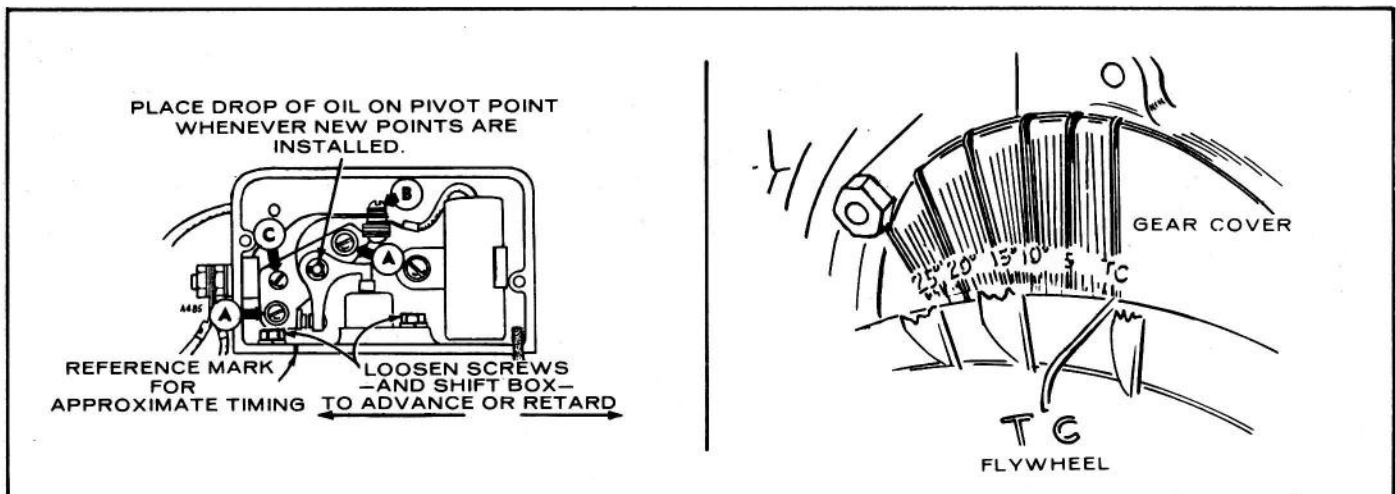

FIGURE 36. IGNITION TIMING

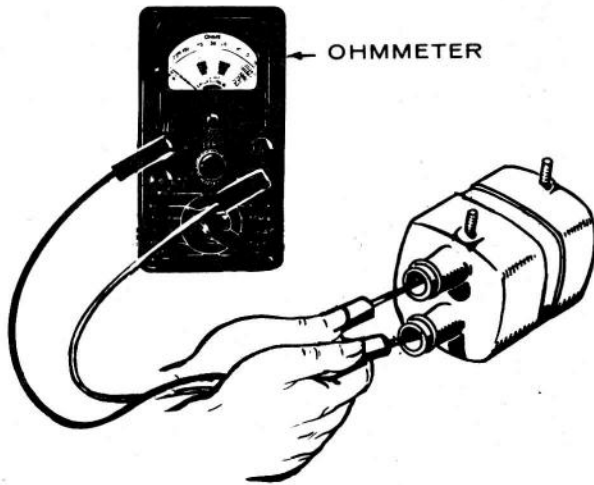

FIGURE 37. TESTING IGNITION COIL

turn the crankshaft with rotation (clockwise)

3. The lamp should go out just as the points break (19° BTC).
4. If timing needs adjustment, loosen the mounting screws on breaker box and move it left to advance or right to retard the timing.

IGNITION COIL

To check ignition coil (Figure 37), first place ohmmeter leads on small terminals. Resistance should read 1/2 to 1-1/2 ohms. Next place ohmmeter leads inside of spark plug cable holes. Resistance should read 10,800 to 13,200 ohms.

SPARK PLUGS

The only service of spark plugs is cleaning, gapping or replacing. See the *PERIODIC MAINTENANCE* section.

BATTERY CHARGING, FLYWHEEL ALTERNATOR

The flywheel alternator is a permanent magnet alternator and uses a solid-state voltage regulator-rectifier for controlling output (Figure 38).

A 30-ampere fuse is included in the battery charging system to protect the alternator in case the battery cables are accidentally reversed. Replace the fuse with Onan Fuse 321-0162, Buss AGC30 or equivalent.

Weak ignition spark or a discharged battery indicate trouble in the charging system. But before testing the engine's charging system, always check the battery for serviceability.

Keep these points in mind when testing or servicing the flywheel alternator:

1. Be sure the output plug (connector) is inserted properly. The plug must bottom in receptacle — eliminates any resistance due to a poor connection. Keep clean and tight.
2. Be sure regulator-rectifier output control has a good ground connection. Mating surface for mounting must be clean and fasteners tightened properly.
3. Never reverse the battery leads.

Regulator-Rectifier Tests

The following tests for the regulator-rectifier require a fully-charged battery.

1. Connect a voltmeter across the battery. Start the engine and operate at 1800 to 3600 rpm.
2. Voltmeter should read 13.4 to 14 volts. If it does, no further testing of the charging system is necessary. If not, install a new regulator-rectifier

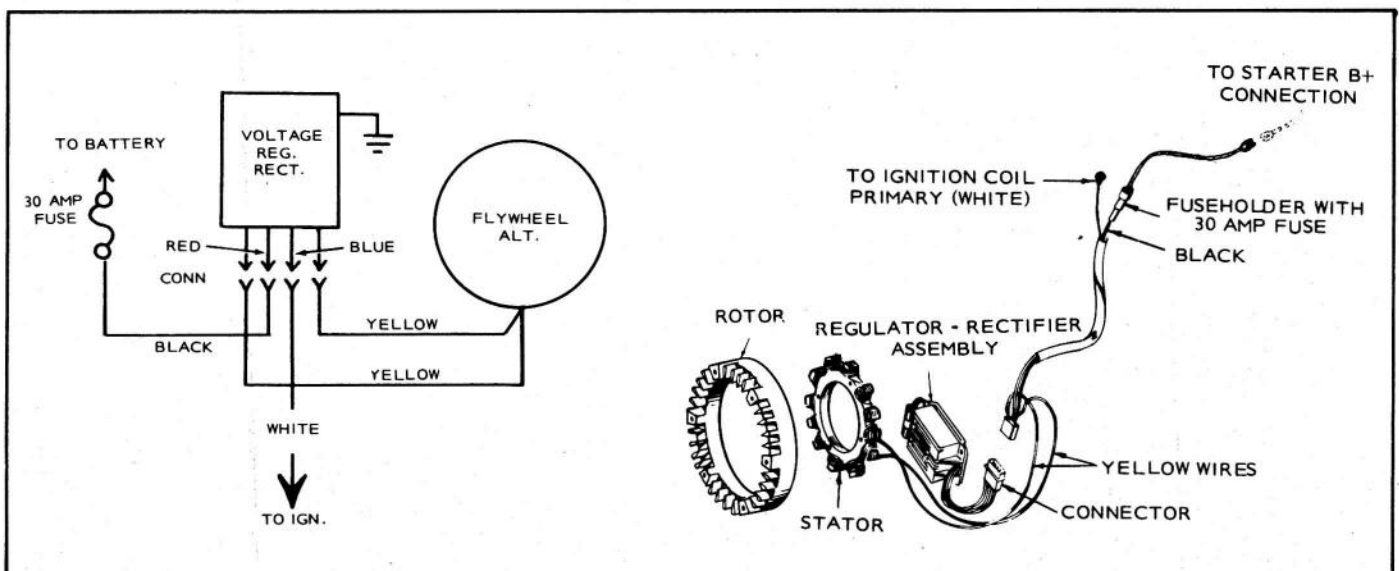

FIGURE 38. FLYWHEEL BATTERY CHARGING ALTERNATOR

and retest. Be sure it has a good ground connection and the connector is properly seated.

Stator Test — Engine Running

1. Before starting the engine, disconnect the connector at the voltage regulator.

WARNING

Be sure engine is stopped before performing step 2. Otherwise, personal injury may result from rotating flywheel.

2. Insert test connectors from AC voltmeter between the two yellow wires (Figure 38).
3. Voltage should be 17 volts or higher. If not, stop engine and check leads to stator. If they are okay, perform next check.

Stator Tests — Engine Not Running

For testing, use a Simpson 270 VOM or equivalent. Be sure test meter and battery, if battery powered, are in good condition. Check with engine NOT running.

1. Set voltage selector switch to DC+ and zero meter on RX1 scale.

Zero the meter before each reading and each time scales are changed.

2. Unplug the connector and connect the meter leads to the two terminals of the female plug with the yellow wires. Meter should read less than 0.8 ohms if stator has continuity. If meter shows no reading, winding is open and stator should be replaced.
3. Touch red meter lead to yellow wire plug terminal and other meter lead to metal core of stator. If meter doesn't read infinity, the stator winding is grounded. Replace the stator.

Flywheel Magnet Group or Rotor

To test the magnet group or rotor, lay a piece of ferrous (iron) material up against the magnets to be sure they are charged. If not, replace the rotor.

If the rotor is removed and replaced, use approximately 5 ft-lb torque (0.69 kg/m) on the mounting bolts.

STARTING SYSTEM

ELECTRIC STARTER

Normally the starter will require little or no service other than possible brush replacement. See Figure 39. However, if through accident or misuse, the starter requires service or overhaul, the following procedures will provide the information necessary to perform this service.

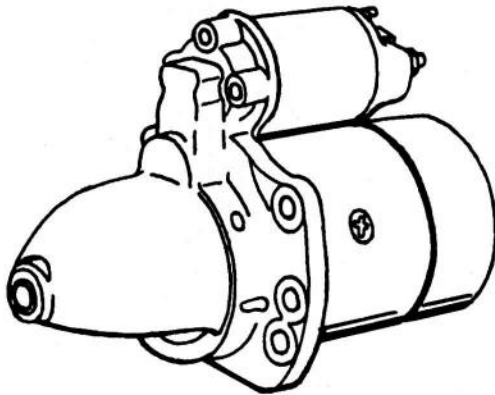

FIGURE 39. STARTER ASSEMBLY

STARTER DISASSEMBLY

1. Loosen the M terminal nut on the solenoid switch and remove the connector to the starter assembly. Then unscrew attaching screws and remove the solenoid switch (Figure 40).

The packings for the solenoid switch are mounted so that the steel packing is located in the front bracket side.

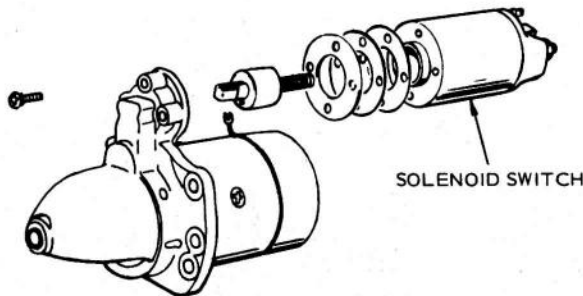

FIGURE 40. SOLENOID SWITCH REMOVAL

2. After removing the through bolts, the starting motor can be divided into three parts — the front bracket, housing and rear bracket. The spacing

washers shown in Figure 41 are used for adjustment of the thrust gap of the armature shaft and are placed between the rear bracket and the commutator.

These washers are inserted so the steel washer is located in the commutator side.

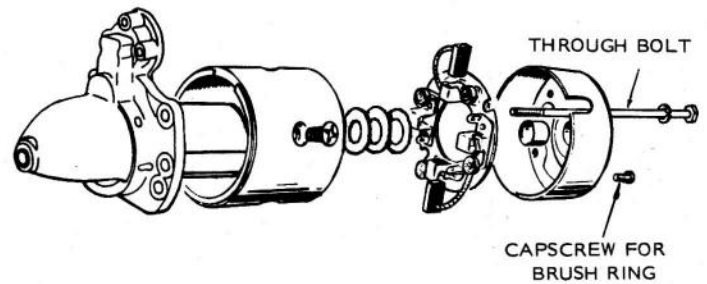

FIGURE 41. REMOVING THROUGH BOLTS

3. The armature can easily be removed from the front bracket. Be careful not to miss a small steel washer used in the end of the armature shaft. The shift lever can be removed along with the armature when it is removed. In this case, the spring holder, lever springs and retainer can be taken out before the lever. See Figure 42.

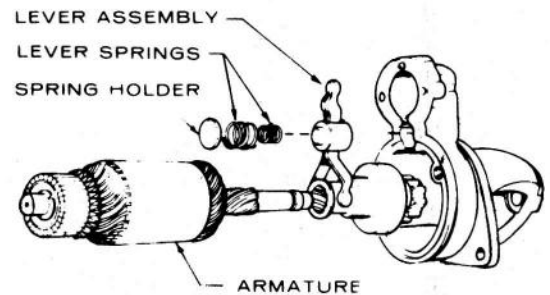

FIGURE 42. ARMATURE REMOVAL

4. Remove the ring after driving the pinion stopper toward the pinion gear using a cylindrical tool as shown in Figure 43. The overrunning clutch and the pinion stopper should be removed simultaneously.
5. Two of the four brushes have been soldered to the brushholder (Figure 44). The brush springs can be removed from the brushholder.

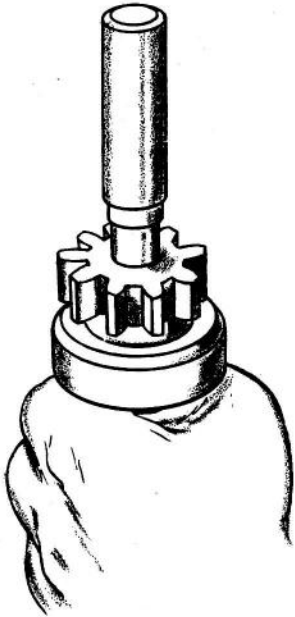

FIGURE 43. RING REMOVAL

brush springs can be removed from the brushholder.

6. The pole shoes may be removed if necessary, by removing the flat head machine screws from the frame.

STARTER REASSEMBLY

Inspect the parts carefully in accordance with the procedure described in "Inspection of Parts". Make any repair necessary. Reassembly is the reverse of disassembly. Take the following precautions.

1. Clean all of the parts carefully with a dry cloth and compressed air if it is available.

CAUTION Do not use steam or high pressure water to clean the starter. Otherwise, water particles are entrapped in the starter after reassembly.

Do not immerse bearing-equipped parts in cleaning fluid. Clean these parts with a brush dipped in "Varsol" or any other comparable mineral spirits. Do not immerse overrunning clutch in cleaning solvent. Thoroughly dry any parts that come into contact with the cleaning fluid.

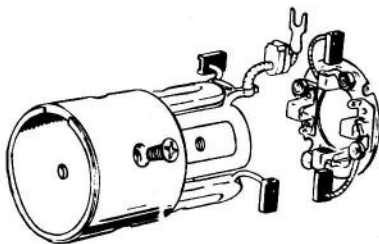

FIGURE 44. STARTER BRUSHES

2. Apply SAE 20 oil to the armature shaft and splines. Apply grease (Shell Albania No. 2 or equivalent) sparingly on the shift lever pin, the joint of the shift lever and plunger, the plunger and spacing washers at the end of the shaft.
3. To mount the overrunning clutch; first insert the pinion stopper into the armature shaft, then apply the ring to the groove of the shaft rigidly. For the insertion of the ring, use a tool as shown in Figure 45 and pull the pinion stopper up.

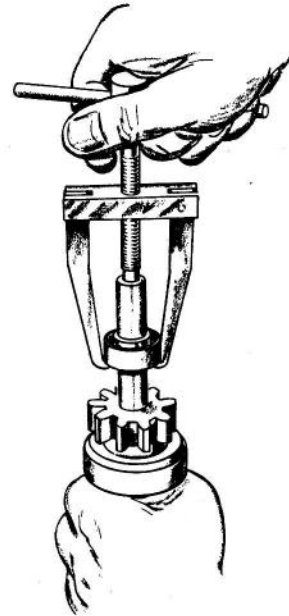

FIGURE 45. MOUNTING OVERRUNNING CLUTCH

4. Use spacing washers to adjust the armature to give end play of 0.004 to 0.02 inch (0.102 to 0.51 mm).
5. Tighten the through bolts to a torque of 35 to 44 in-lbs. (0.40 to 0.51 kg/m).
6. Insert the shift lever as shown in Figure 46 into the front bracket.

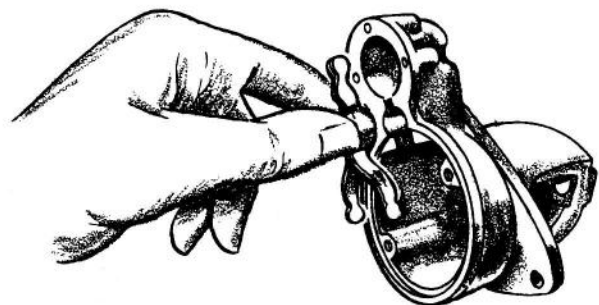

FIGURE 46. INSTALLING SHIFT LEVER

INSPECTION OF PARTS

Testing Armature for Short Circuits

Place the armature in a growler and hold a thin steel blade parallel to the core and just above it while slowly rotating the armature in the growler (Figure 47). A shorted armature will cause the blade to vibrate and be attracted to the core. Replace shorted armature.

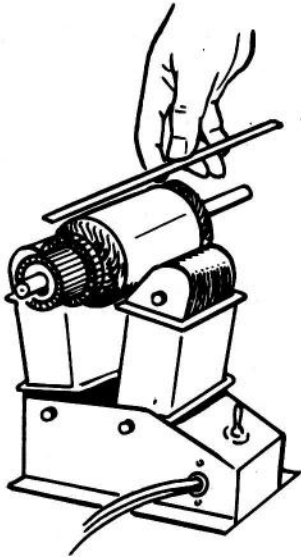

FIGURE 47. ARMATURE SHORT CIRCUIT TEST

Testing Armature for Grounds

Touch armature shaft or core and the end of each commutator bar with a pair of ohmmeter leads (Figure 48). If the ohmmeter reading is low, it indicates a grounded armature. Replace grounded armature.

Testing Armature for Open Circuit

The most likely place for an open to occur is at the commutator riser bars. Inspect the points where the

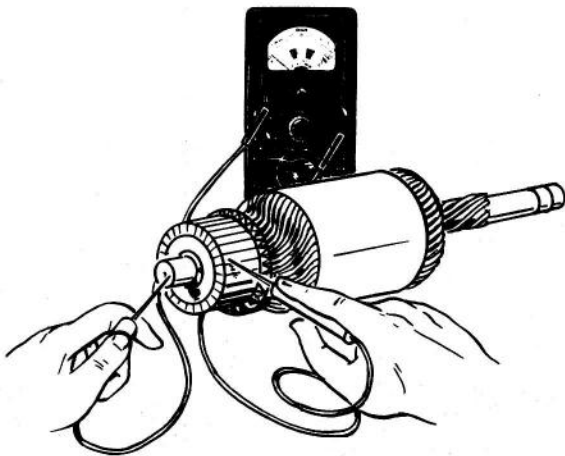

FIGURE 48. ARMATURE GROUND TEST

conductors are joined to the commutator bars for loose connections.

Testing Commutator Runout

Place armature in a test bench and check runout with a dial indicator (Figure 49). When commutator runout exceeds 0.004 inch (0.102 mm) reface the commutator.

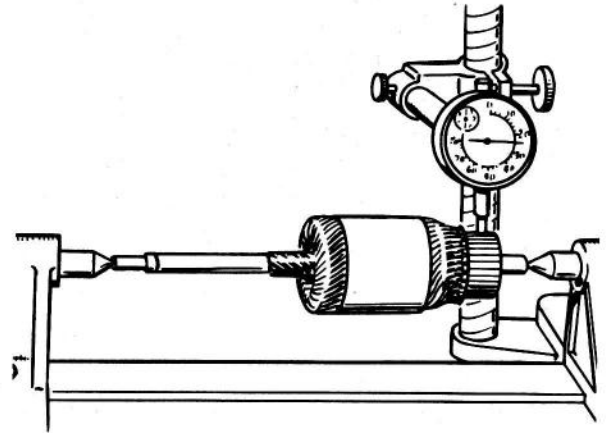

FIGURE 49. CHECKING COMMUTATOR RUNOUT

Testing Armature Shaft Runout

The armature shaft as well as the commutator may be checked. See Figure 50. A bent armature often may be straightened, but if the shaft is worn, a new armature is required.

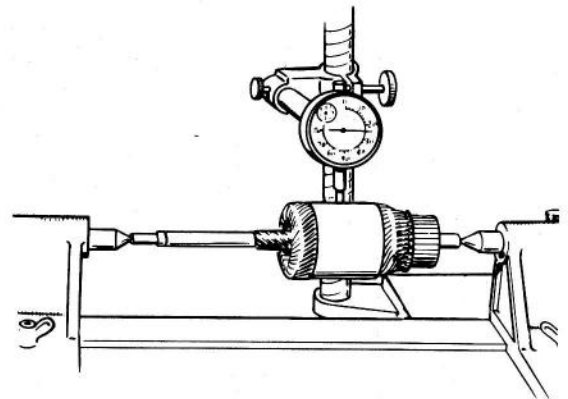

FIGURE 50. CHECKING ARMATURE SHAFT RUNOUT

Testing Field Coils for Grounds

Place one lead on the connector and the other on a clean spot on the frame after unsoldering the shunt field coil wire (Figure 51). If the ohmmeter reading is low, the fields are grounded, either at the connector or in the windings.

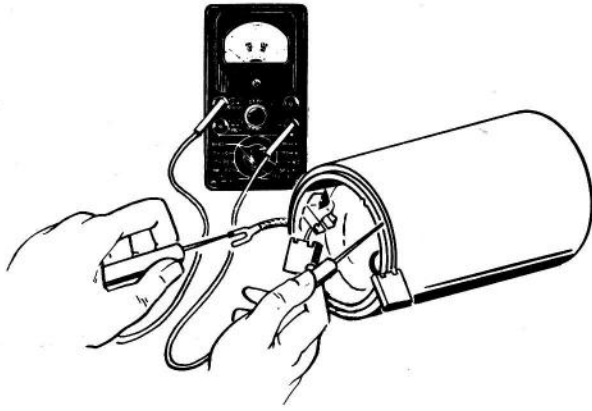

FIGURE 51. FIELD COIL GROUND TEST

Testing Field Coils for Open Circuit

Place one lead on the connector and the other on a clean spot on the brushholder (Figure 52). If the ohmmeter reading is high, the field coil is open. Check the other three brushholders in the same manner.

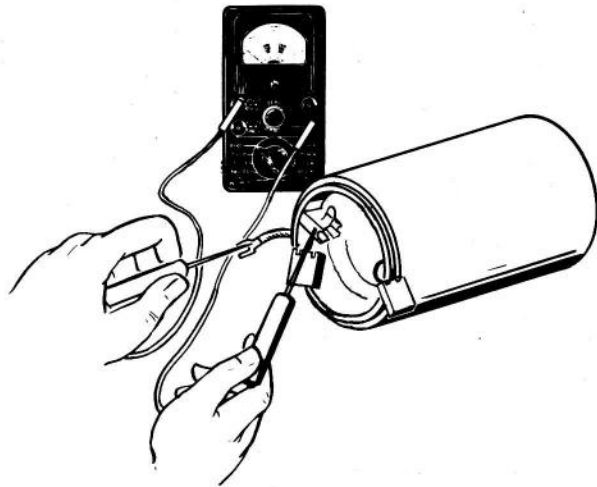

FIGURE 52. FIELD COIL OPEN CIRCUIT TEST

Inspection of Brushes

When brushes are worn to the wear limits as shown in Figure 53, replace them. See that the brushes move smoothly in the brushholders.

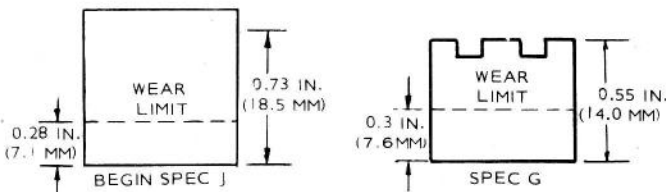

FIGURE 53. BRUSH WEAR LIMITS

Inspection for Brush Spring Tension

Measure brush spring tension with a tension meter as shown in Figure 54. Push the brush and take a reading just as the brush projects a little from the brushholder. On a new brush the spring tension should be 49 to 59 ounces (1390 to 1670 grams) for begin Spec J CCKA engines, 29 to 38 ounces (820 to 1075 grams) for Spec G engines.

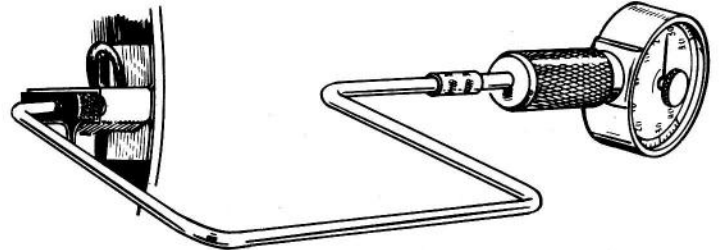

FIGURE 54. MEASURING BRUSH SPRING TENSION

INSPECTION AFTER OVERHAUL

1. For no load test, the starting motor is wired as shown in Figure 55 and run. The value of the meter reading at this condition should be as follows:

	Begin Spec J	Spec G Only
Voltage	10.5	11.5
RPM	5000	3700
Max. Current Draw (Amp)	53	60

The conductor for this test should be large enough and as short as possible. If anything is wrong in the above test,

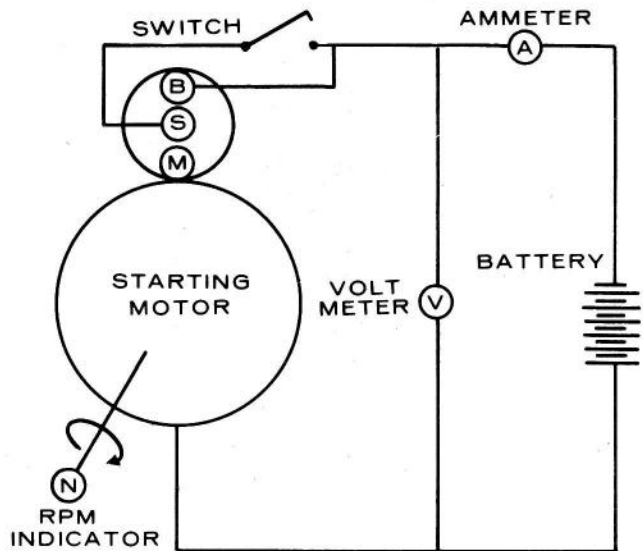

FIGURE 55. WIRING STARTER FOR NO LOAD TESTS

inspect the following items:

Annealed brush springs
Improperly seated brushes
Insufficient armature endplay
Shorted, open or grounded armature
Grounded or open field coil
Poor electrical connection
Dirty commutator

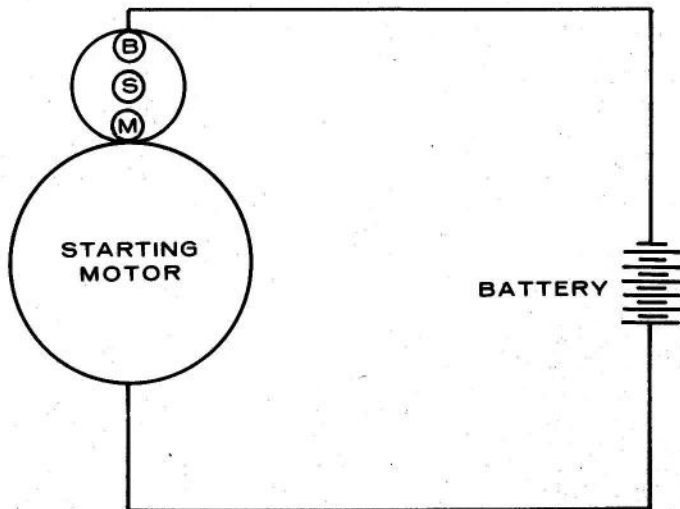

FIGURE 56. BATTERY CONNECTIONS

2. To adjust pinion clearance, connect the battery to the starting motor as shown in Figure 56. This will allow the pinion of the starting motor to slide and stop. In this state, measure the clearance between the end of the pinion and pinion stop when the pinion is pushed lightly toward the commutator end. Clearance should be 0.02 to 0.06 inch (0.51 to 1.52 mm). Adjust for proper clearance by removing the solenoid switch attaching screws and select the proper thickness of the fiber packings shown in Figure 57.

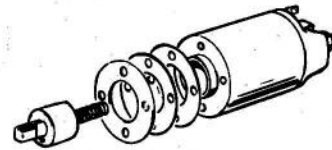

FIGURE 57. ADJUSTING PINION CLEARANCE

PARTS CATALOG

INSTRUCTIONS FOR ORDERING REPAIR PARTS

For parts or service, contact the dealer from whom you purchased this equipment or refer to your Nearest Authorized Onan Parts and Service Center.

To avoid errors or delay in filling your parts order, please furnish all information requested.

Always refer to the nameplate on your unit:

1. Always give the MODEL and SPEC NO. and SERIAL NO.

Onan MODEL AND SPEC NO [REDACTED]	
SERIAL NO [REDACTED]	
IMPORTANT ALWAYS GIVE ABOVE NOS WHEN ORDERING PARTS	
HORSEPOWER	16.5
OIL CAPACITY	2 QUARTS
CHECK OIL LEVEL DAILY BELOW 30 F - SAE 5W20 ABOVE 30 F - SAE 30	
CHANGE OIL AFTER FIRST 5 HOURS CHANGE OIL EVERY 40 OPERATING HOURS, EVERY 20 HOURS DUSTY CONDITIONS	
FUEL	REGULAR GASOLINE
BATTERY	12V NEG GND
DO NOT REVERSE BATTERY CONNECTIONS	
VALVES (COLD)	IN 010. EXH 012
SPARK PLUG GAP	025
POINT GAP	020
MANUFACTURED BY ONAN DIVISION OF ONAN CORPORATION MINNEAPOLIS, MINNESOTA, U.S.A. 99A1135	

For handy reference, insert YOUR engine nameplate information in the spaces above.

2. Do not order by reference number or group number; always use part number and description.
3. Give the part number, description and quantity needed of each item. If an older part cannot be identified, return the part prepaid to your dealer or nearest AUTHORIZED SERVICE STATION. Print your name and address plainly on the package. Write a letter to the same address stating the reason for returning the part.
4. State definite shipping instructions. Any claim for loss or damage to your unit in transit should be filed promptly against the transportation company making the delivery. Shipments are complete unless the packing list indicates items are back ordered.

Prices are purposely omitted from this Parts Catalog due to the confusion resulting from fluctuating costs, import duties, sales taxes, exchange rates, etc.

For current parts prices, consult your Onan Dealer, Distributor or Parts and Service Center.

"En esta lista de partes los precios se omiten de proposito, ya que bastante confusion resulto de fluctuaciones de los precios, derechos aduanales, impuestos de venta, cambios extranjeros, etc."

Consiga los precios vigentes de su distribuidor de productos "ONAN".

This catalog applies to the CCKA Engines listed below. Parts are arranged in groups of related items. Each illustrated part is identified by a reference number corresponding to the same reference number following the illustration. Parts illustrations are typical. Using the MODEL and SPEC NO. from the engine nameplate, select the PARTS KEY NO. (1,2, etc., in the last column) that applies to your Engine Model and Spec No. This PARTS KEY NO. represents parts that differ between models. Unless otherwise mentioned in the description, parts are interchangeable between models. Right and left engine sides are determined by FACING the blower end (front) of the engine.

MODEL AND SPEC NO.	PARTS KEY NO.
CCKA-MS/1831G*	1
CCKA-MS/1897G*	2
CCKA-MS/1949G*	3
CCKA-MS/2043G*	4
CCKA-MS/2111G*†	5
CCKA-MS/2813J*	6
CCKA-MS/3110J*	7
CCKA-MS/3612J*	8

* - The Specification Letter Advances (A to B, B to C, etc.) with manufacturing changes.

† - CCKA-MS/2567G is replacement engine for CCKA-MS/2111G and is identical.

INDEX

GROUP TITLE	PAGE NUMBER
INTRODUCTION.....	35
DATA TABLE	35
Alternator, Flywheel	44
Block, Cylinder	36,37
Camshaft	39
Carburetor Parts	43
Crankshaft	40
Fuel System	41
Gear Cover	47
Governor	46
Housing, Blower	46
Ignition	45
Oil System	38
Piston and Connecting Rod	39
Pump Parts, Fuel	42
Service Kits and Miscellaneous	47
Starter Motor	44
Valve Cover and Oil By-Pass	37

CYLINDER BLOCK

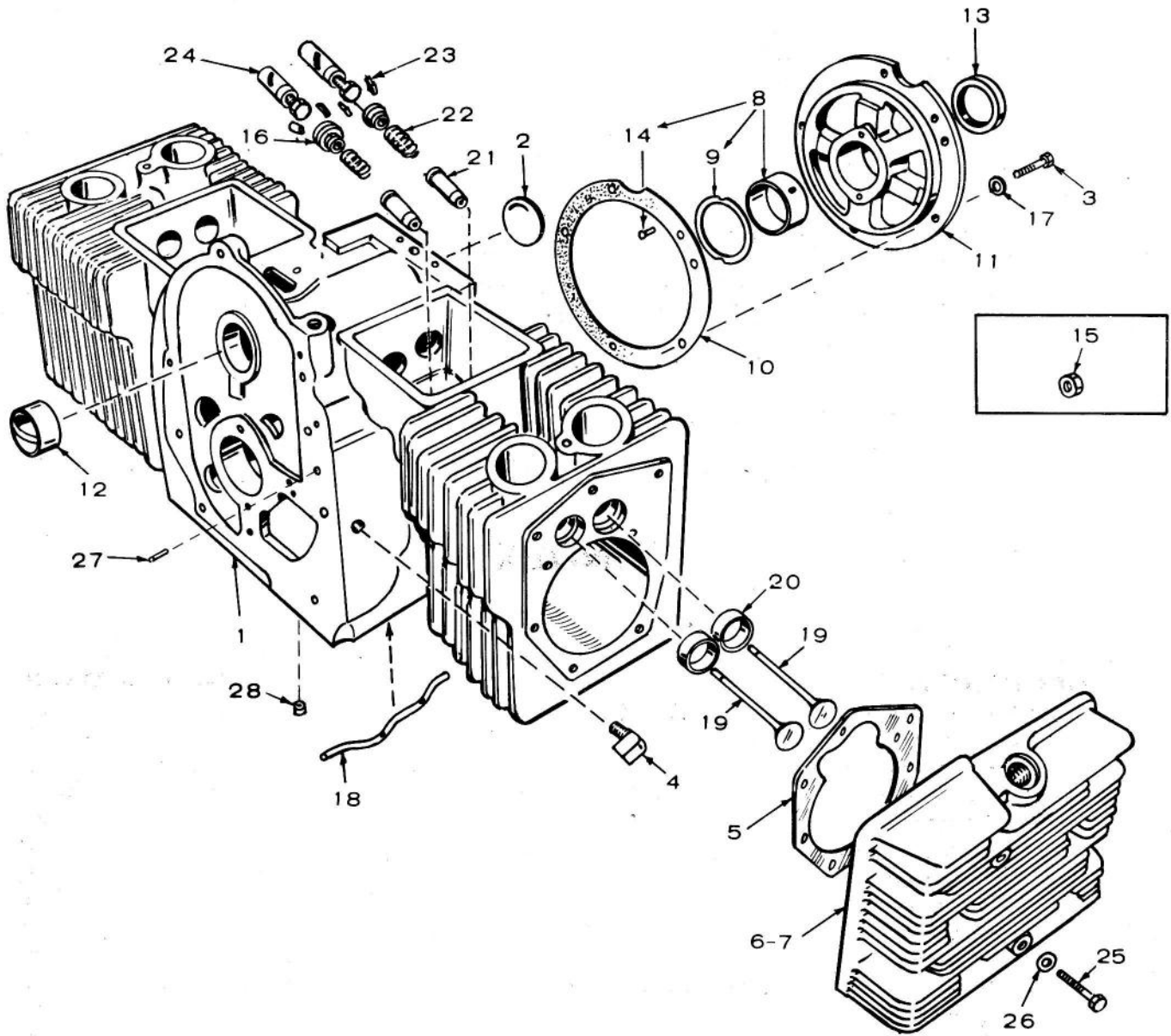

CYLINDER BLOCK

REF. NO.	PART NO.	QTY. USED	PART DESCRIPTION	REF. NO.	PART NO.	QTY. USED	PART DESCRIPTION
1	BLOCK ASSEMBLY			16	110-0904	4	Rotocap, Valve
	110-1770	1	Key 1,2,3,4	17	851-0005	5	Washer, Lock - Rear Bearing Plate (Special)
	110-1911	1	Key 5,6,7,8	18	120-0386	1	*Tube, Crankcase Oil
2	517-0048	1	*Plug, Camshaft Expansion	19	VALVE		
3	800-0512	5	Screw, Cap - Hex Head Rear Bearing, Plate Mounting (5/16-18 x 1")		110-1037	2	Intake
4	502-0020	1	Elbow, Street - Oil Line (Keys 1,2,3,4 & 5)		110-0880	2	Exhaust
5	110-0892	2	Gasket, Cylinder Head	20	INSERT, VALVE SEAT		
6	110-0884	1	Head, Cylinder - Right (#2 Cylinder)		110-0872	2	*Exhaust, Standard
7	110-0883	1	Head, Cylinder - Left (#1 Cylinder)		110-0872-02	2	Exhaust, .002" Oversize
8	BEARING, CRANKSHAFT				110-0872-05	2	Exhaust, .005" Oversize
	101-0450	2	*Standard		110-0872-10	2	Exhaust, .010" Oversize
	101-0450-02	2	.002" Undersize		110-0872-25	2	Exhaust, .025" Oversize
	101-0450-10	2	.010" Undersize		110-1000	2	*Intake, Standard
	101-0450-20	2	.020" Undersize		110-1000-02	2	Intake, .002" Oversize
	101-0450-30	2	.030" Undersize		110-1000-05	2	Intake, .005" Oversize
9	104-0575	2	*Washer, Crankshaft Bearing Thrust		110-1000-10	2	Intake, .010" Oversize
10	*GASKET KIT, BEARING PLATE				110-1000-25	2	Intake, .025" Oversize
	101-0413	1	Key 1,2,3,4	21	110-0902	4	*Guide, Valve
	101-0115	1	Key 5,6,7,8	22	110-0539	4	Spring, Valve
11	101-0316	1	*Plate, Bearing (Excludes Bearing)	23	110-0639	8	Lock, Valve and Spring Retaining
12	101-0367	2	*Bearing, Camshaft Front or Rear (Precision)	24	TAPPET, VALVE		
13	509-0041	1	*Seal, Bearing Plate		115-0006	4	Standard
14	516-0072	4	*Pin, Main Bearing Stop		115-0006-05	4	.005" Oversize
15	110-0445	5	*Nut, Rear Bearing Plate (Key 1,2,3,4,5,8)	25	SCREW, CAP HEX HEAD		
					110-0879	8	5/16-18 x 1-1/4" lg (Special)
					114-0022	10	5/16 x 1-3/4" lg (Special)
				26	526-0122	18	Washer, Flat - Cylinder Head Mounting (11/32" I.D. x 23/32" O.D. x 10 Ga. Thk)
				27	516-0011	2	*Pin, Dowel - Gearcase Alignment
				28	517-0090	1	Plug, Wet Hole (Plastic)

* - Parts included in Cylinder Block Assembly.

VALVE COVER AND OIL BY-PASS

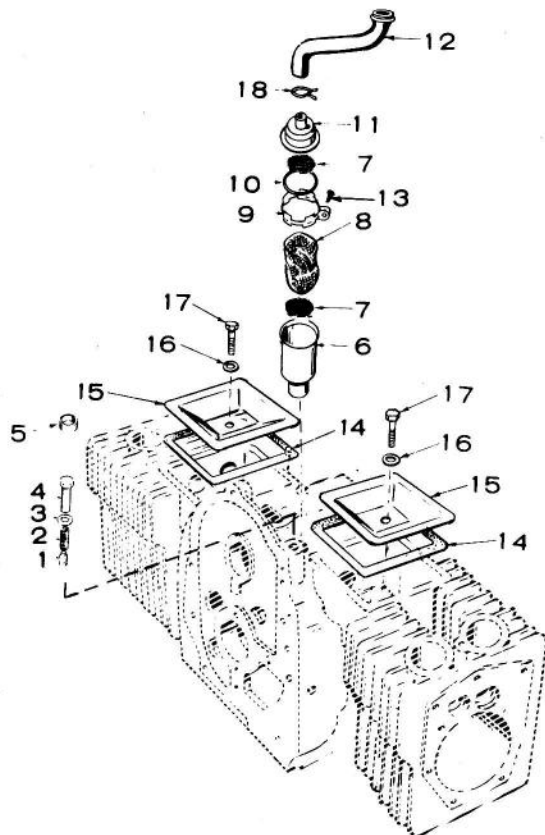

REF. NO.	PART NO.	QTY. USED	PART DESCRIPTION
1	123-0398	1	Valve, Oil By-Pass
2	120-0140	1	Spring, Oil By-Pass Valve
3	526-0066	1	Washer, Flat, Oil Pressure Relief Valve (25/64" ID x 9/16" OD x 1/16" Thk)
4	120-0187	1	Stud, Oil By-Pass Adjustment (Includes Nuts) Keys 1,2,3,4
4	801-0050	1	Screw, Cap - Hex Head Oil By-Pass Adjustment Key 5 (3/8-24 x 1" lg)
4	801-0048	1	Screw, Cap - Hex Head - Oil By-Pass Adjustment (5/16-18 x 1" lg) - Key 6,7,8
5	120-0704	1	Spacer, Oil By-Pass (Key 5 Only)
6	123-0953	1	Tube, Breather
7	123-0958	2	Screen, Breather Tube
8	123-0865	1	Baffle, Breather Tube
9	123-0951	1	Clamp, Breather Cap
10	509-0117	1	Seal "O" Ring - Breather Tube
11	123-0954	1	Cap, Breather Tube
12	TUBE, BREATHER		
	503-0574	1	Keys 1,2,3,4,5
	123-1264	1	Key 6,7,8
13	809-0035	1	Screw, Cap - Hex Head - Breather Cap Clamp (#8 x 3/4" lg)
14	110-0667	2	Gasket, Valve Cover
15	110-0666	2	Cover, Valve Cover
16	526-0063	2	Washer, Flat - Valve Cover Mounting (17/64" ID x 7/16" OD x 1/32" Thk)
17	800-0012	2	Screw, Cap - Hex Head - Valve Cover Mounting (3/8-16 x 2" lg)
18	503-0170	1	Clamp, Breather Hose

OIL SYSTEM

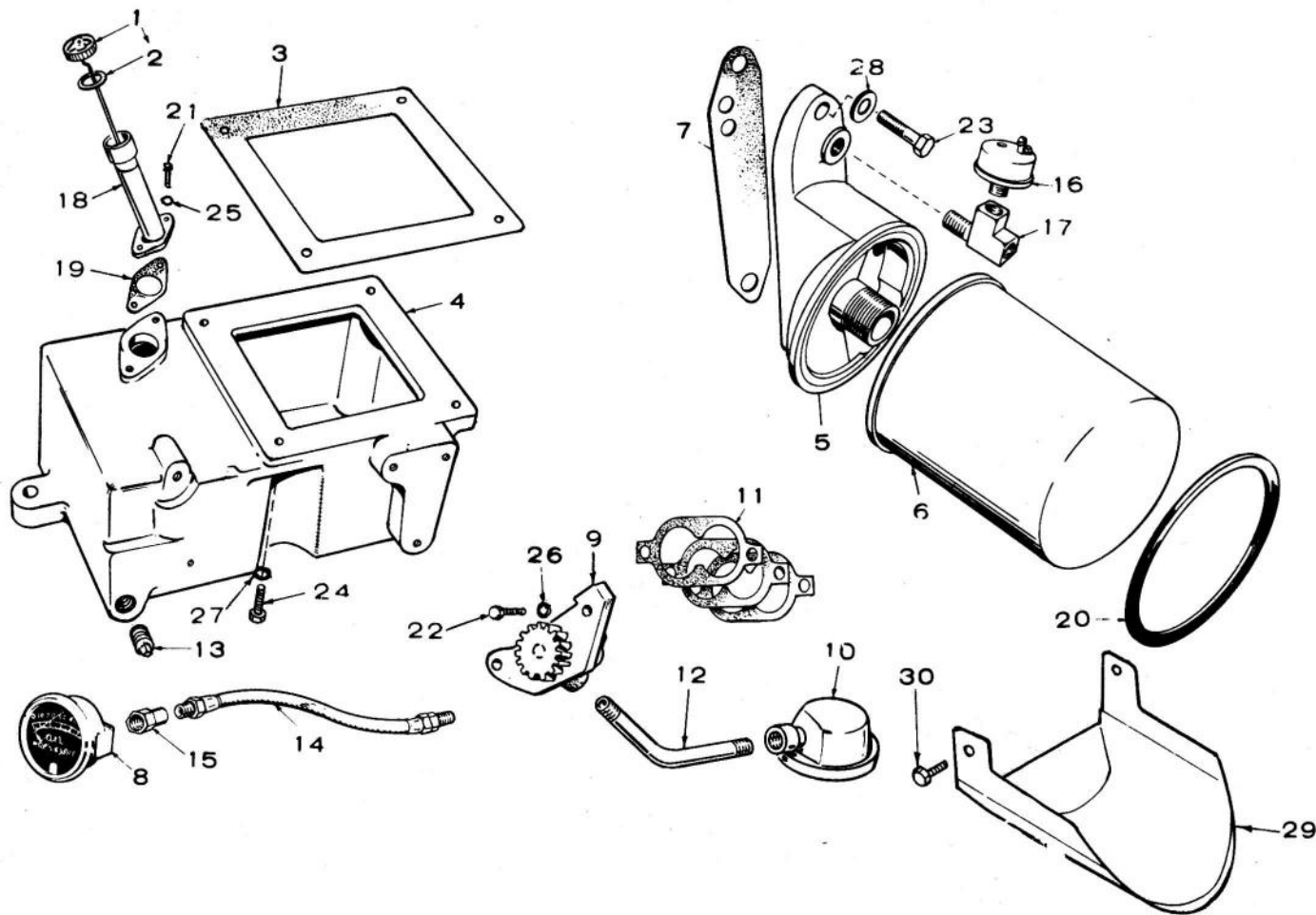

REF. NO.	PART NO.	QTY. USED	PART DESCRIPTION	REF. NO.	PART NO.	QTY. USED	PART DESCRIPTION
1	123-1102	1	Cap & Indicator, oil Fill	17	502-0058	1	Tee, Low Oil Pressure Switch - Key 4,5,6,7,8
2	123-0191	1	Gasket, Oil Fill Cap	18	123-0674	1	Tube, Oil Fill
3	102-0158	1	Gasket, Oil Base Mounting	19	141-0078	1	Gasket, Oil Fill Tube Mounting
4	102-0655	1	Base, Oil	20	122-0347	1	Seal, Air - Oil Filter
5	122-0320	1	Adapter, Oil Fill	21	800-0005	2	Screw, Cap - Hex Head - Oil Fill Tube Mounting (1/4-20 x 3/4" lg)
6	122-0323	1	Filter, Oil (Spin-On)	22	800-0007	2	Screw, Cap - Hex Head - Oil Pump Mounting (1/4-20 x 1" lg)
7	122-0321	1	Gasket, Oil Filter Adapter	23	800-0028	2	Screw, Cap - Hex Head - Oil Filter Adapter Mounting (5/16-18 x 1" lg)
8	193-0005	1	Gauge, Oil Pressure - Key 1,2,3	24	102-0455	4	Screw, Cap - Hex Head - Oil Base Mounting (3/8-16 x 1" lg)
9	120-0491	1	Pump, Oil - Complete (NOTE: Internal parts not sold separately)	25	850-0040	2	Washer, Lock - Spring - Oil Fill Tube Mounting (1/4")
10	120-0663	1	Intake, Oil Pump (Includes Cup and Screen)	26	850-0040	2	Washer, Lock - Spring - Oil Pump Mounting (1/4")
11	120-0161	1	Gasket Kit, Oil Pump	27	850-0050	4	Washer, Lock - Spring - Oil Base Mounting (3/8")
12	120-0689	1	Line, Oil Pump Intake	28	526-0065	2	Washer, Flat - Oil Filter Adapter Mounting (21/64" ID x 9/16" OD x 1 1/16" Thk)
13	505-0056	1	Plug, Oil Drain	29	122-0352	1	Pan, Oil Drain
14	501-0003	1	Line, Oil Gauge (Flexible)	30	815-0194	2	Screw, Tapping - Hex Head with ET (#10-32 x 3/8")
15	502-0017	1	Connector, Oil Line				
16	309-0237	1	Switch, Low Oil Pressure - Key 4,5,6,7,8				

CAMSHAFT

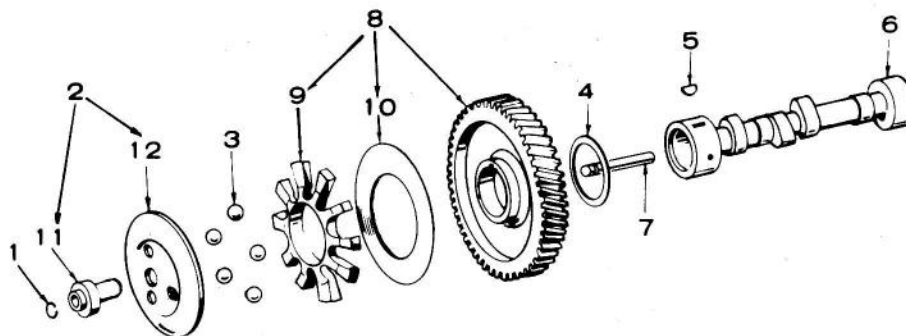

REF. NO.	PART NO.	QTY. USED	PART DESCRIPTION
1	150-0078	1	Ring, Camshaft Center Pin
2	150-1695	1	Kit, Governor Cup
3	510-0015	5	Ball, Fly - Governor
4	105-0004	1	Washer, Camshaft Gear Thrust
5	515-0001	1	Key, Camshaft Gear Mounting
6	105-0238	1	Camshaft (Includes Pin)
7	150-0075	1	Pin, Camshaft Center
8	105-0332	1	Gear, Camshaft (Includes Parts Marked *)
9	150-1257	1	*Spacer, Flyball
10	150-0077	1	*Plate, Flyball
11	150-1519	1	Hub, Governor Cup
12	150-1520	1	Cup, Governor

* - Parts included in 105-0332 Camshaft Gear

PISTON AND CONNECTING ROD

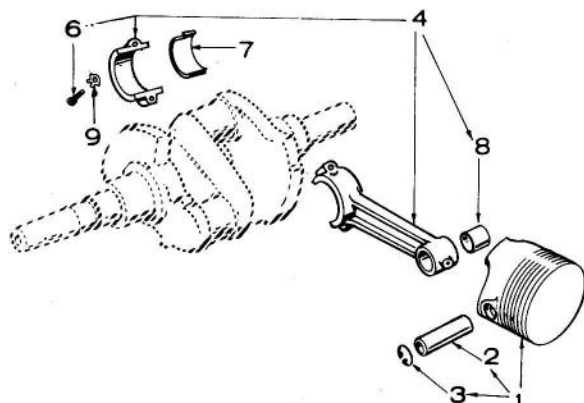
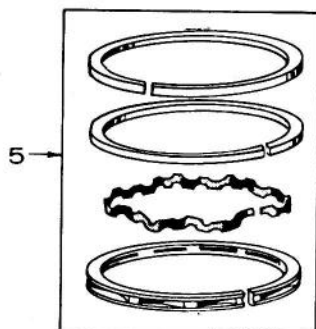

REF. NO.	PART NO.	QTY. USED	PART DESCRIPTION
1	PISTON & PIN (Includes Retaining Rings)		
	112-0136	2	Standard
	112-0136-05	2	.005" Oversize
	112-0136-10	2	.010" Oversize
	112-0136-20	2	.020" Oversize
	112-0136-30	2	.030" Oversize
	112-0136-40	2	.040" Oversize
2	PIN, PISTON		
	112-0069	2	Standard
3	112-0003	4	Ring, Piston Pin Retaining
4	114-0203	2	Rod Assembly, Connecting (Forged) Includes Bushing and Place Bolts
5	RING SET, PISTON		
	113-0153	2	Standard
	113-0153-05	2	.005" Oversize
	113-0153-10	2	.010" Oversize
	113-0153-20	2	.020" Oversize
	113-0153-30	2	.030" Oversize
	113-0153-40	2	.040" Oversize
6	805-0010	4	Bolt, Place - Connecting Rods (5/16-24 x 1/4" lg)
7	BEARING, CONNECTING ROD		
	114-0145	4	Standard
	114-0145-02	4	.002" Undersize
	114-0145-10	4	.010" Undersize
	114-0145-20	4	.020" Undersize
	114-0145-30	4	.030" Undersize
8	114-0036	2	Bushing, Piston Pin - Connecting Rod
9	114-0059	4	Washer, Connecting Rod Screw Lock

CRANKSHAFT

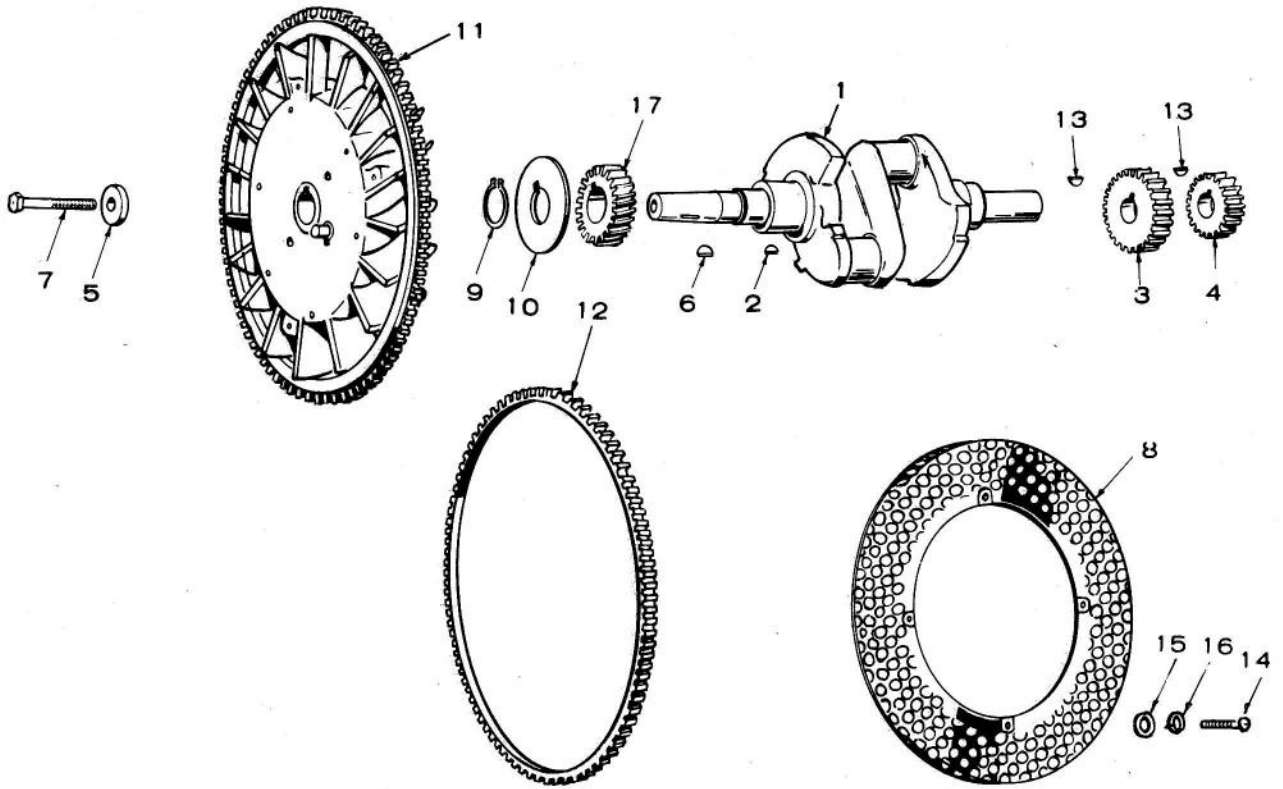

REF. NO.	PART NO.	QTY. USED	PART DESCRIPTION
1	CRANKSHAFT		
	104-0710	1	Key 1,2,3 & 4
	104-0774	1	Key 5
	104-0885	1	Key 6,7,8
2	515-0001	1	Key, Crankshaft Gear Mounting
3	190-0284	1	*Gear, Transmission Drive (3-3/16") - Key 4
4	190-0285	1	*Gear, Transmission Drive (2-5/16") - Key 4
5	526-0128	1	Washer, Flywheel Mounting
6	515-0098	1	Key, Flywheel Mounting
7	104-0170	1	Screw, Flywheel Mounting (Special)
8	134-1889	1	Screen, Flywheel
9	518-0014	1	Lock, Crankshaft Gear Washer
10	104-0043	1	Washer, Crankshaft Gear Retaining
11	134-2556	1	Flywheel (Includes Ring Gear)
12	134-0673	1	Gear, Ring - Flywheel
13	515-0094	2	*Key, Transmission Drive Gears - Key 4
14	812-0125	3	Screw, Roundhead (12-29 x 1/2") Guard Mounting
15	526-0006	3	Washer, Flat (#12) - Guard Mounting
16	850-0035	3	Washer, Lock (#12) - Guard Mounting
17	104-0032	1	Gear, Crankshaft

* - Order these parts from the tractor manufacturer.

FUEL SYSTEM

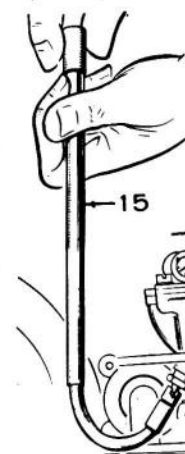
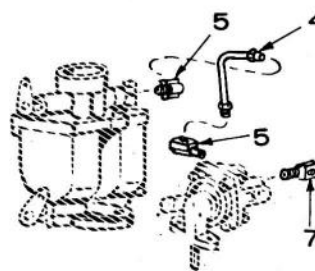
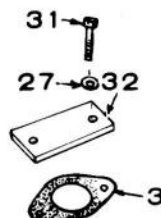
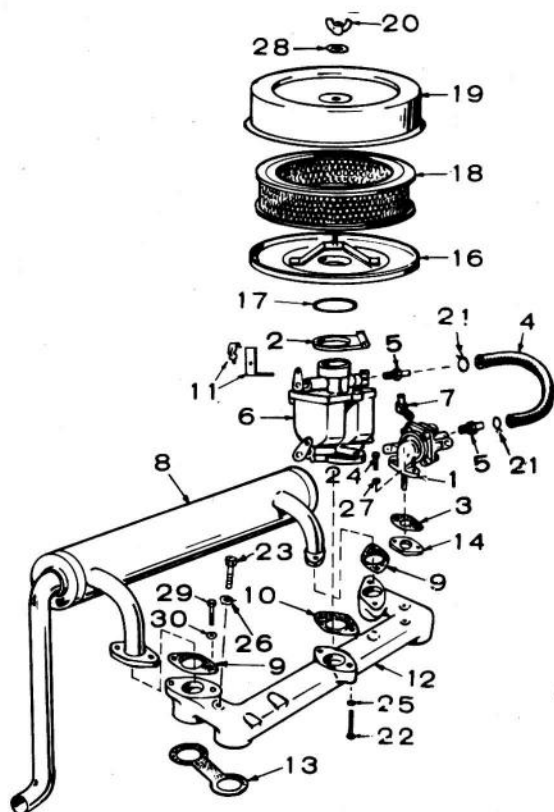

REF. NO.	PART NO.	QTY. USED	PART DESCRIPTION
1	149-0693	1	Pump, Fuel - Key 1,2,3,4,5,6,7 (See Separate Group for Components)
2	140-1058	1	Clamp, Air Cleaner
3	GASKET 149-0003	2	Key 1,2,3,4,5,6,7
	149-0003	1	Key 8
4	LINE, FUEL 149-0611	1	Key 1,2,3,4,5
	503-0694	1	Key 6,7
5	CONNECTOR, FUEL LINE 502-0002	2	Key 1,2,3,4,5 - (1) Fuel Pump Outlet, (1) Carburetor Inlet
	502-0395	2	Key 6,7 - (1) Fuel Pump Outlet, (1) Carburetor Inlet
	502-0395	1	Key 8 - Carburetor Inlet
6	CARBURETOR (See Separate Group for Components) 142-0482	1	Key 1,2,3,4
	142-0593	1	Key 5,6,7,8
7	CONNECTOR, FUEL LINE 502-0020	1	Key 1,2,3,4,5 (Fuel Pump Inlet)
	502-0313	1	Key 6,7 (Fuel Pump Inlet)
8	MUFFLER, EXHAUST 155-1065	1	Keys 1,2,3
	155-0480	1	Key 4,5,6,7,8
9	154-0360	2	Gasket, Muffler
10	141-0078	1	Gasket, Carburetor Mounting
11	153-0263	1	Bracket and Clip, Choke Cable
12	154-0356	1	Manifold, Intake
13	154-0013	2	Gasket, Intake Manifold
14	149-0045	1	Spacer, Fuel Pump Mounting
15	420-0169	1	Wrench, Carburetor Adjusting
16	BASE, AIR CLEANER 140-1054	1	Key 1,2,3,4,5
	140-1206	1	Key 6,7,8

REF. NO.	PART NO.	QTY. USED	PART DESCRIPTION
17	509-0124	1	Seal, "O" Ring - Air Cleaner
18	140-1055	1	Element, Air Cleaner
19	140-1053	1	Cover, Air Cleaner
20	865-0022	1	Nut, W/ing - Air Cleaner
21	503-0301	2	Clamp, Fuel Hose
22	800-0009	2	Screw, Cap - Hex Head Carburetor Mounting (1/4-20 x 1-1/2" lg)
23	800-0054	2	Screw, Cap - Hex Head - Intake Manifold Mounting (3/8-16 x 2" lg)
24	815-0222	2	Screw, Machine - Fillister Head Fuel Pump Mounting (1/4-20 x 1-1/4" lg)
25	850-0040	2	Washer, Lock - Spring - Carburetor Mounting (1/4")
26	850-0050	2	Washer, Lock - Spring - Intake Manifold Mounting (3/8")
27	526-0063	2	Washer, Flat - Fuel Pump Mounting (17/64" ID x 7/16" OD x 1/32" Thk)
28	526-0008	1	Washer, Flat - Air Cleaner Cover Mounting (13/64" ID x 7/16" OD x 1/32" Thk)
29	800-0028	4	Screw, Cap - Hex Head (5/16"-18 x 1")
30	850-0045	4	Washer, Lock - Spring (5/15")
31	800-0004	2	Screw, Cap - Hex Head (1/4-20 x 5/8")
32	149-0136	1	Plate, Fuel Pump Hole - Key 8

FUEL PUMP PARTS

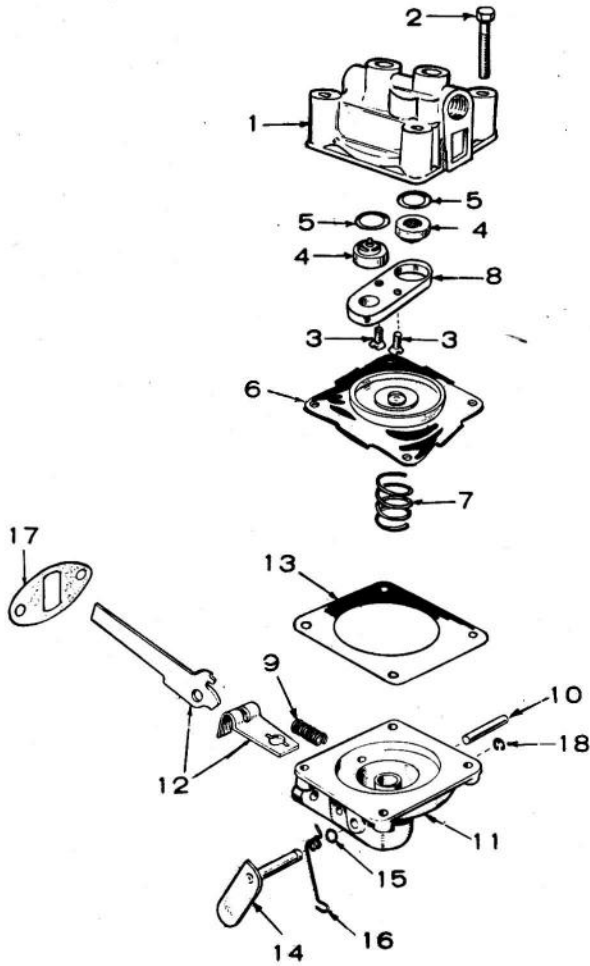

REF. NO.	PART NO.	QTY. USED	PART DESCRIPTION
	149-0693	1	Pump, Fuel - Key 1,2,3,4,5,6,7
	149-0526	1	Repair Kit (Includes Parts Marked *)
1		1	Body (Not Sold Separately)
2	815-0148	4	Screw, Self Tapping (#8-32 x 7/8")
3	815-0147	2	Screw, Phillips Self Tapping (#6-32 x 5/8") - Retainer
4	149-0096	2	*Valve and Cage
5	149-0095	2	*Gasket, Valve
6	149-0582	1	*Diaphragm Assembly
7	149-0672	1	*Spring
8	149-0539	1	Retainer, Valve Cage
9	149-0675	1	*Spring
10	516-0113	1	Pin, Rocker Arm
11		1	Body (Not Sold Separately)
12	149-0710	1	Link and Arm, Rocker (Sold Only as a Set)
13	149-0858	1	*Gasket, Diaphragm - Lower Side
14	149-0551	1	Lever, Primer
15	509-0065	2	Seal, "O" Ring
16	149-0404	1	Spring, Primer Lever
17	149-0003	1	*Gasket, Pump Mounting
18	518-0129	1	Ring, Retainer - Primer Lever

* - Parts Included in 149-0526 Repair Kit.

CARBURETOR PARTS

REF. NO.	PART NO.	QTY. USED	PART DESCRIPTION
CARBURETOR			
	142-0482	1	Key 1,2,3,4
	142-0593	1	Key 5,6,7,8
	142-0371	1	Repair Kit, Carburetor - Includes Parts Marked **)
	142-0033	1	Gasket Kit, Carburetor - Includes Parts Marked *)
1	815-0103	1	Screw, Bowl Cover
1	815-0109	2	Screw, Bowl Cover
2	815-0091	2	**Screw, Choke Fly (4-40 x 3/16")
3	142-0055	1	Fly, Choke
4	142-0205	1	Sleeve Assembly, Choke (Cover)
5	SHAFT ASSEMBLY, CHOKE		
	142-0420	1	Key 1,2,3,4
	142-0530	1	Key 5,6,7,8
6	142-0039	1	**Shaft, Float
7	142-0031	1	*Gasket, Body to Bowl
8	148-0017	2	*Gasket (1) Float Valve Seat (1) Main Adjusting Needle
9	142-0049	1	**Valve and Seat Assembly
10	142-0032	1	*Gasket, Nozzle
11	142-0285	1	Nozzle Assembly
12	142-0361	1	Float and Lever Assembly
13	145-0008	1	Lever, Idle Stop
14	142-0040	1	**Needle, Idle Adjusting
15	142-0282	1	Spring, Idle Needle Adjusting
16	142-0035	1	Spring, Throttle Stop Adjusting Screw
17	812-0063	1	Screw, Throttle Stop Adjusting (3/4-32 x 1/2")
18	815-0072	2	**Screw, Throttle Fly (4-40 x 1/4")
19	142-0369	1	Fly, Throttle
20	142-0368	1	**Shaft Assembly, Throttle
21	142-0370	1	Nut and Jet Nozzle
22	142-0046	1	Retainer, Main Adjusting Needle
23	142-0206	1	**Packing, Main Adjusting Needle
24	142-0045	1	Retainer, Main Adjusting Needle Packing
25	516-0027	1	Pin, Main Adjusting Needle
26	142-0041	1	*Needle, Main Adjusting
27		1	Body Assembly (Not Sold Separately)
28	505-0008	1	Plug, Gas Inlet
29	142-0042	1	Needle Assembly (Includes Packing, Nut and Retainer)
30	142-0343	2	**Bushing, Throttle Shaft
31	870-0053	1	Nut, Throttle Stop
32	813-0103	1	Screw, Throttle Stop Clamp
33	142-0227	1	Pin, Choke Stop

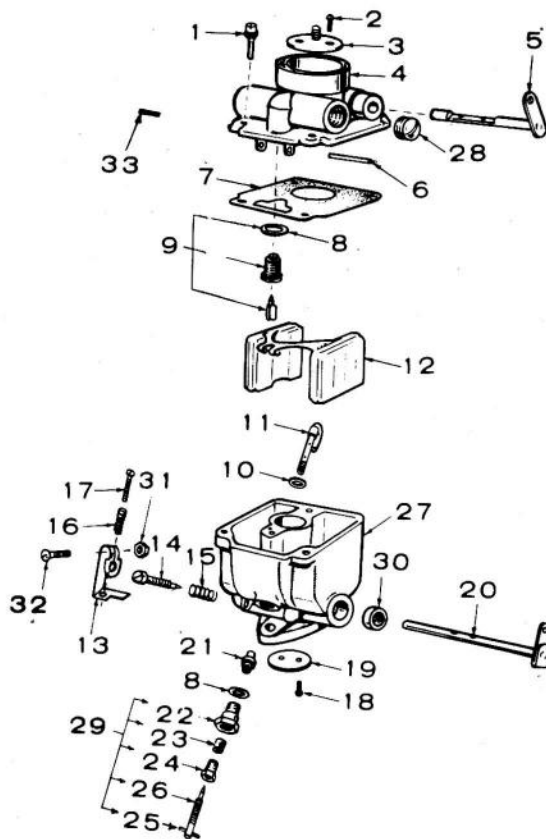

* - Parts contained in 142-0033 Gasket Kit.

** - Parts contained in 142-0371 Repair Kit.

FLYWHEEL ALTERNATOR

REF. NO.	PART NO.	QTY. USED	PART DESCRIPTION
1	191-0739	1	Key 1,2,3,4
	191-0892	1	Key 5,6,7,8
2	191-0400	1	Rotor, Charging Alternator
3	305-0478	1	Regulator, Rectifier
4	305-0477	1	Spacer, Regulator Mounting
5	323-0488	4	*Socket, Connecting
6	323-0789	1	*Housing, Connecting Sockets
7	321-0165	1	*Holder, Fuse
8	321-0162	1	*Fuse (30 Amp)
9	332-0529	1	*Terminal, Faston
10	332-1338	2	Clamp, Loop Type
11	332-1358	1	Bracket, Connector Mounting
12	191-0793	1	Clip, Wiring Harness
13	812-0156	6	Screw, Machine - Round Head Rotor Mounting (1/4-20 x 1-1/2" lg)
14	813-0109	3	Screw, Machine - Round Head - Stator Mounting (#10-32 x 1-3/4" lg)
15	850-0040	9	Washer, Lock - Spring (1/4")
16	850-0030	3	Washer, Lock - Spring (#10)
17	800-0006	2	Screw, Cap - Hex Head (1/4-20 x 7/8")
18	800-0009	1	Screw, Cap - Hex Head (1/4-20 x 1-1/2")
19	800-0047	2	Screw, Cap - Hex Head (3/8-16 x 5/8")

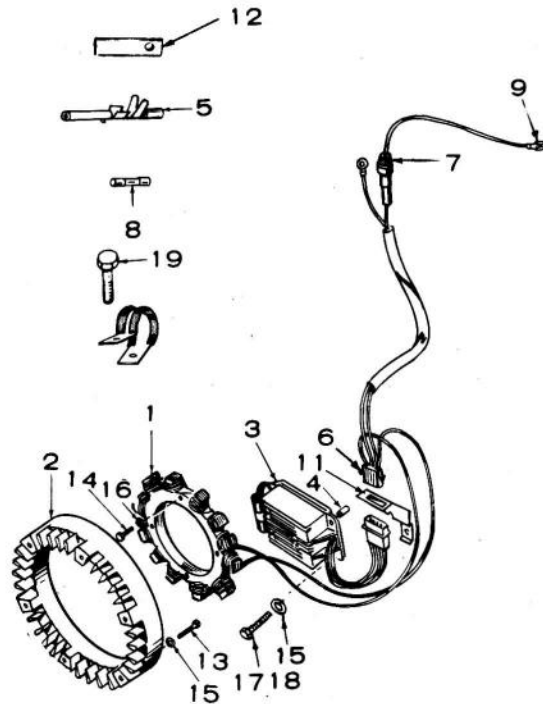

* - Parts included in Charging Alternator Stator

STARTER MOTOR

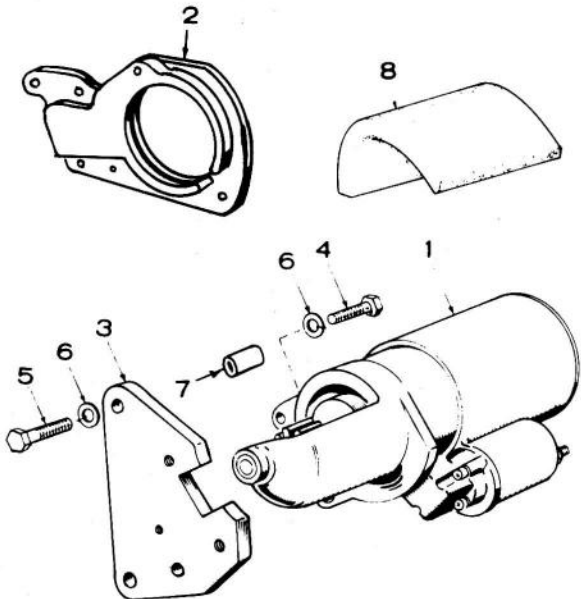

REF. NO.	PART NO.	QTY. USED	PART DESCRIPTION
1	MOTOR, STARTING (For Components see Separate Group)		
	191-0511	1	Key 1
	191-0790	1	Key 3,4,5
	191-0734	1	Key 2
	191-1052	1	Key 6,7,8
2	191-1104	1	Flange, Starter Motor Mounting
3	£	1	Bracket, Starter Motor Mounting - Key 2
4	800-0050	2	Screw, Cap - Hex Head Starter Motor to Bracket (3/8-16 x 1" lg)
5	102-0455	3	Screw, Cap - Hex Head Starter Bracket Mounting (3/8-16 x 1" lg)
6	850-0050	5	Washer, Lock - Spring - Starter Motor Mounting (3/8")
7	191-1103	2	Spacer, Starter Mounting
8	191-1108	1	Seal, Air

£ - Refer to factory giving complete Model, Spec and Serial Number

IGNITION

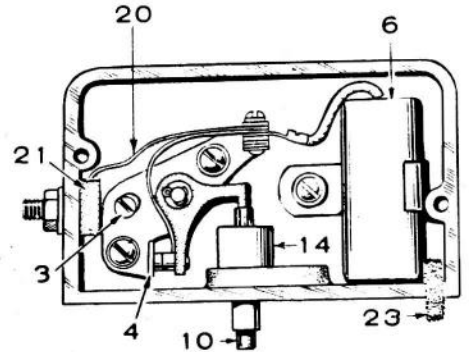
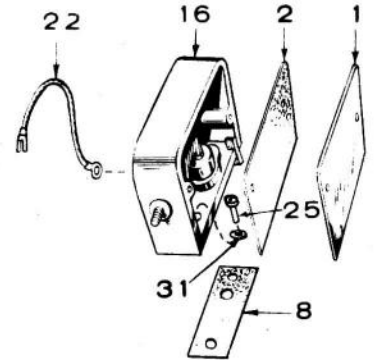
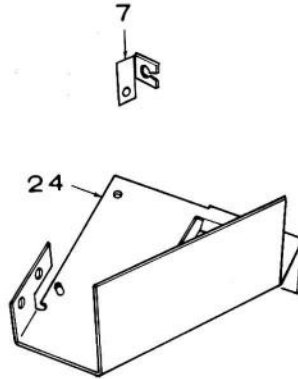
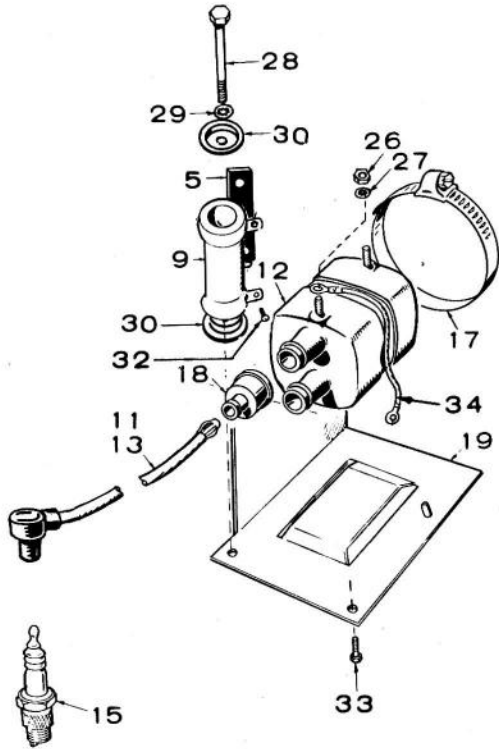

REF. NO.	PART NO.	QTY. USED	PART DESCRIPTION	REF. NO.	PART NO.	QTY. USED	PART DESCRIPTION
1	160-0930	1	Cover, Breaker Box	17	503-0514	1	Clamp, Coil
2	160-0150	1	Gasket, Breaker Box Cover	18	160-0558	2	Nipple, Rubber - Coil
3	160-0075	1	Cam, Point Gap Adjusting	19	166-0376	1	Bracket, Coil Mounting - Key 1,2,3
4	160-0002	1	Point Set, breaker	20	160-0428	1	Strap, Point Set to Terminal Block
5	304-0610	1	Support, Resistor Terminal	21	160-0349	1	Block and Terminal Assembly
6	312-0069	1	Condenser, Breaker Points	22	334-0028	1	Lead (4 ft. piece of wire)
7	167-0188	1	Clip, Spark Plug Cables	23	160-0261	1	Wick, Breaker Box Oil Drain
8	160-0043	1	Gasket, Breaker Box Mounting	24	166-0562	1	Bracket, Coil Mounting - Key 4,5,6,7,8
9	304-0060	1	Resistor, Ignition	25	802-0034	2	Screw, Cap - Socket Head
10	160-0262	1	Plunger Assembly (Includes Plunger and Guide)	26	870-0053	2	Nut, Coil Terminal (10-32)
11	CABLE, SPARK PLUG - RIGHT			27	854-0010	2	Washer, Coil Terminal (#10)
	167-1594	1	8-1/2" - Key 1,2,3,4,5,6	28	813-0112	1	Screw, Resistor Mounting (10-32 x 2-1/2")
	167-1596	1	7-1/4" - Key 7,8	29	850-0030	1	Washer, Lock - Resistor Mounting (#10-)
12	166-0346	1	Coil, Ignition	30	304-0014	2	Washer, Centering - Resistor Mounting
13	CABLE, SPARK PLUG - LEFT			31	850-0040	2	Washer, Lock - Spring (1/4")
	167-1594	1	Key 1,2,3	32	815-0201	2	Screw, Machine - Round Head with ET (#8-32 x 3/8")
	167-1593	1	17-1/2" - Key 4,5,6	33	821-0004	2	Screw, Cap - HWH (#10-32 x 5/16")
	167-1595	1	17" - Key 7,8	34	336-0332	1	Lead, Coil
14	160-0263	1	Diaphragm, Breaker Box				
15	PLUG, SPARK						
	167-0241	2	Key 1,2,3,4,5,6				
	167-0237	2	Key 7,8				
16	160-0257	1	Box, Breaker (Includes Points, Condenser, Cover and Gasket)				

BLOWER HOUSING GROUP

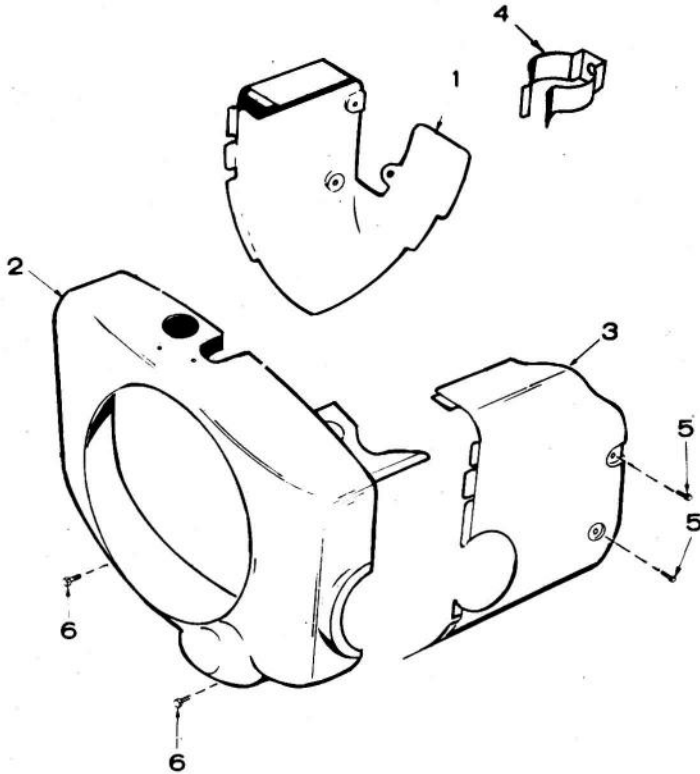

REF. NO.	PART NO.	QTY. USED	PART DESCRIPTION
1	134-0589	1	Housing, Cylinder Air - Left
2	HOUSING, BLOWER		
	134-2025	1	Key 1,2,3
	134-2199	1	Key 4,5
	134-2951	1	Key 6,7,8
3	HOUSING, CYLINDER AIR - RIGHT		
	134-2032	1	Key 1
	134-2094	1	Key 2,3,4,5
	134-2954	1	Key 6,7,8
4	321-0169	1	Clip, Cylinder Air Housing
5	815-0261	5	Screw, Tapping - HWH (1/4-20 x 1/2")
6	821-0010	2	Screw, Cap - HWH (1/4-20 x 1/2")

GOVERNOR GROUP

REF. NO.	PART NO.	QTY. USED	PART DESCRIPTION
1	SPRING, GOVERNOR		
	150-0698	1	Key 1,2,3
	150-1264	1	Key 4,5,6,7,8
2	150-0639	1	Joint, Ball
3	150-0629	1	Link, Throttle
4	518-0006	1	Clip, Link End
5	152-0155	1	Swivel, Throttle Cable Connector - Key 4,5,6,7,8
6	150-1310	1	Bracket, Throttle Control Key 4,5,6,7,8
7	145-0412	1	Connector, Throttle Bracket - Key 4,5,6,7,8
9	815-0104	1	Screw Machine - Fillister Head Throttle Control Swivel - Key 4,5,6,7,8 (#8-32 x 5/16" lg)
10	815-0241	1	Screw, Machine - Truss Head Throttle Control Bracket Key 4,5,6,7 (1/4-20 x 1/2" lg)
11	516-0059	1	Key, Cotter - Throttle Control - Key 4,5,6,7,8
12	526-0006	1	Washer, Flat - Throttle Control (15/64" ID x 1/2" OD x 3/64" Thk)
13	862-0001	1	Nut, Hex - Throttle Control (1/4-20)
14	850-0040	1	Washer, Lock - Spring Throttle Control (1/4)
15	870-0053	1	Nut, Hex - Governor Control (10-32)
16	870-0131	1	Nut, Keps - Governor Control (Includes Washer #10-32)
17	150-1269	1	Spacer, Throttle Control Bracket - Key 4, 5, 6, 7, 8

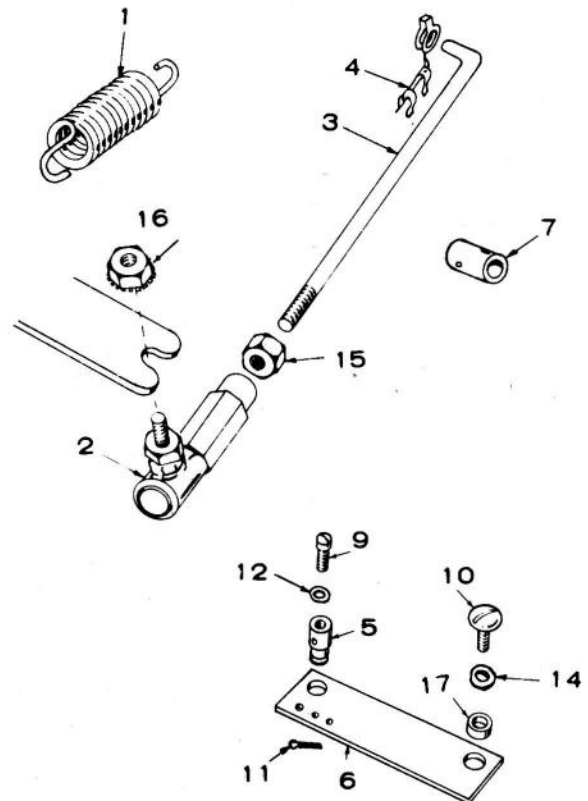

GEAR COVER GROUP

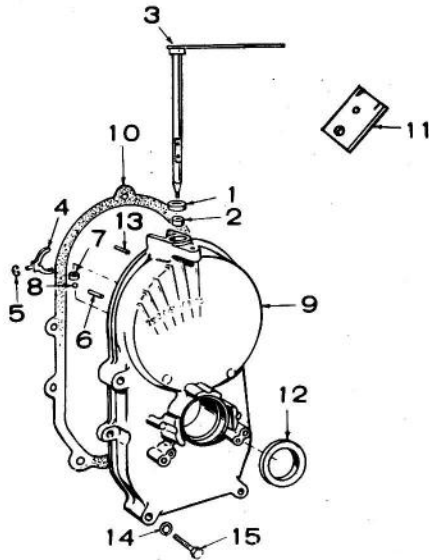

REF. NO.	PART NO.	QTY. USED	PART DESCRIPTION
1	509-0008	1	*Seal, Oil - Governor Shaft
2	510-0013	1	*Bearing - Governor Shaft - Upper
3	150-0377	1	*Shaft and Arm Assembly, Governor
4	150-0620	1	*Yoke, Governor Shaft
5	518-0129	1	*Ring, Yoke Retainer
6	516-0130	1	*Pin - Governor - Cup Stop
7	510-0008	1	*Bearing, Governor Shaft - Lower
8	510-0014	1	*Ball, Bearing - Governor Shaft
9	103-0332	1	Cover Assembly - Gear (Includes parts marked *)
10	103-0011	1	Gasket, Gear Cover
11	BRACKET, GOVERNOR LINKAGE		
	150-0635	1	Key 1;2,3
	150-1297	1	Key 4,5,6,7,8
12	509-0040	1	*Seal, Gear Cover
13	516-0011	2	Pin, Gear Cover (5/16 x 1-1/8")
14	850-0045	5	Washer, Lock - Spring Gearcover Mounting (5/16")
15	SCREW, CAP - HEX HEAD - GEARCOVER MOUNTING		
	800-0032	4	5/16-18 x 1-3/4" lg)
	800-0034	1	5/16-18 x 2-1/4" lg)

* - Parts Included in Gear Cover Assembly.

SERVICE KITS AND MISCELLANEOUS

NOTE: For other kits, refer to the group for the part in question.

REF. NO.	PART NO.	QTY. USED	PART DESCRIPTION
	168-0109	1	Gasket Kit, Complete Engine
	160-0836	1	Ignition Tune-Up Kit
	168-0095	1	Carbon Removal Gasket Kit
	522-0259	1	Kit, Overhaul

WIRING DIAGRAMS

CCKA-MS/1897G, CCKA-MS/1949G, CCKA-MS/2043G, CCKA-MS/2111G, CCKA-MS/2813J

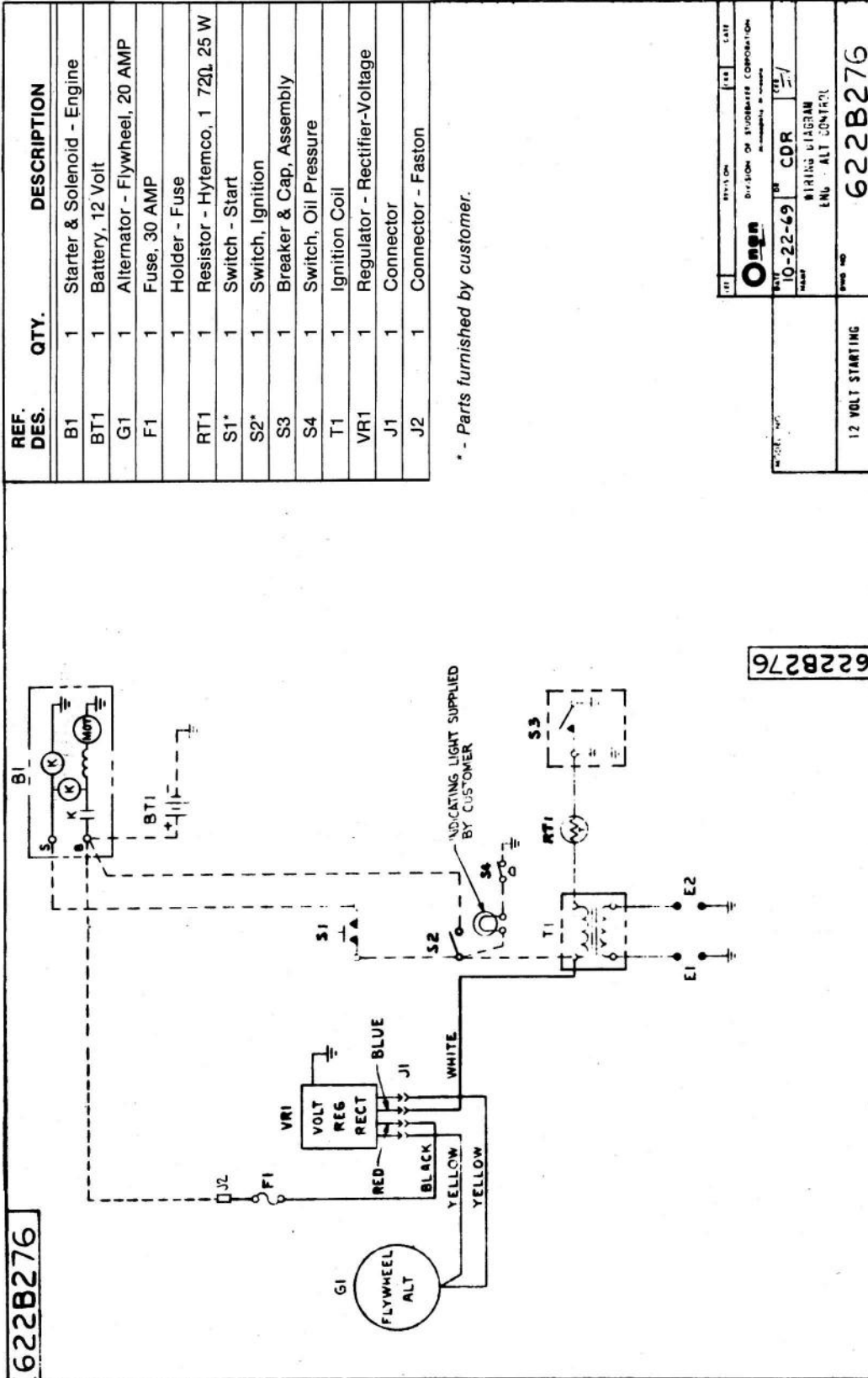

CCKA-MS/1831G

622B260

REF	DES.	QTY	PARTS LIST REF	DESCRIPTION
B1		1	STARTER	12V
BT1		1	BATTERY	12V
G1		1	ALTERNATOR - FLYWHEEL	20 AMP
F1		1	FUSE	30 AMP
		1	HOLDER	- FUSE
K1		1	SOLENOID	- START
RT1		1	RESISTOR	- HYEMUD 1 720. 25 W
S1		1	SWITCH	- START
S2		1	SWITCH	- IGNITION
S3		1	BREAKER & CAP ASSEMBLY	
T1		1	IGNITION COIL	
VRI		1	REGULATOR - RECTIFIER	- VOLTAGE
J1		1	CONNECTOR	

* PARTS FURNISHED BY CUSTOMER

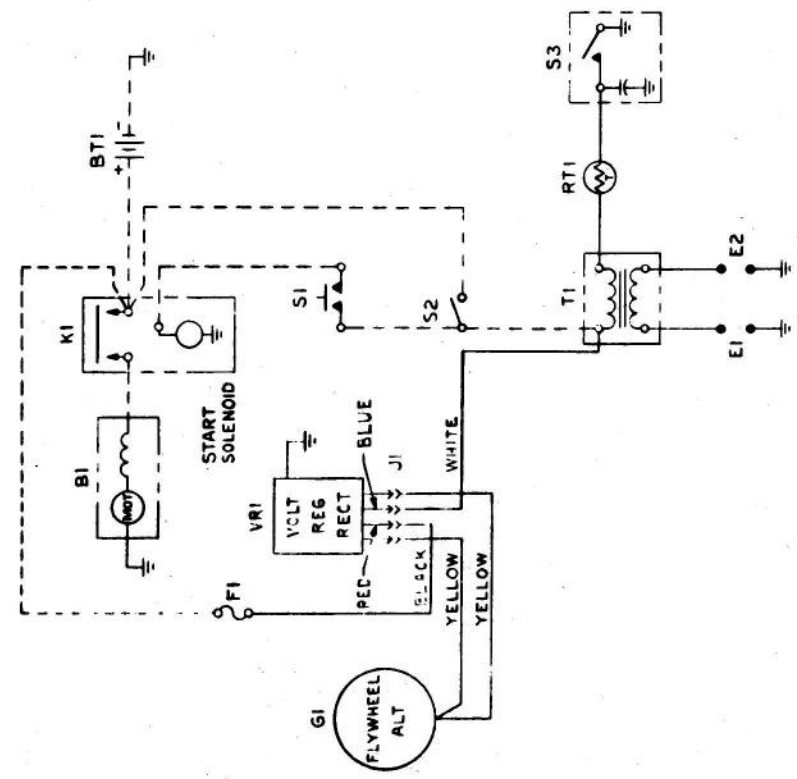

622B260

REV	DATE	BY	CHK
1	2-25-53		
DIVISION OF STUDWATER CORPORATION			
NAME			
WIRING DIAGRAM			
ENG - ALT CONTROL			
REV NO			
622B260			

CCKA-MS/1831G
12 VOLT STARTING

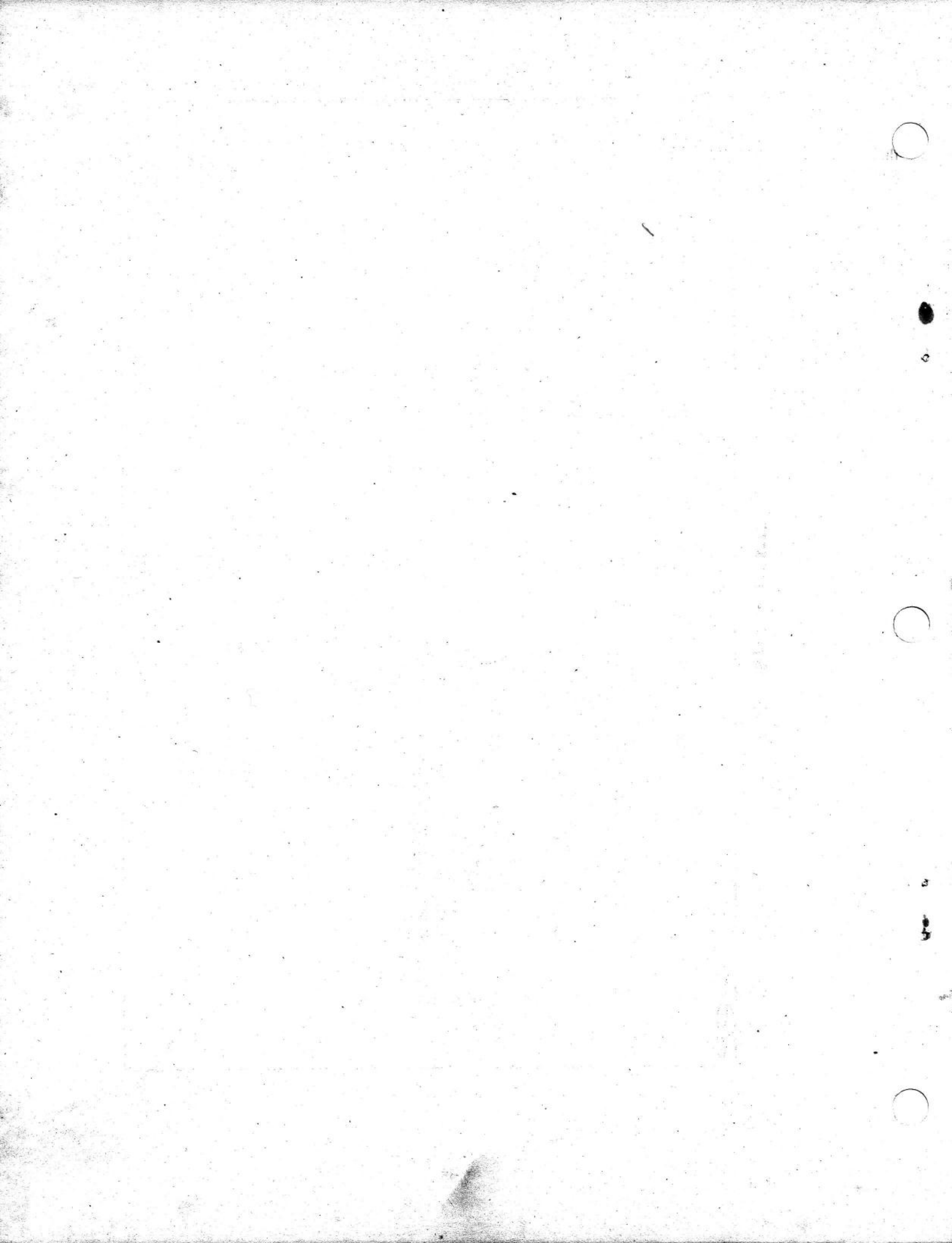

HARDWARE IDENTIFICATION

Illustrated hardware items are only for identification purposes. All hardware items listed throughout this parts catalog are steel SAE grade five (5) or lower (zinc plated with clear chromate dip) unless parts description indicates differently. All dimensions are in inches.

WASHER TYPES

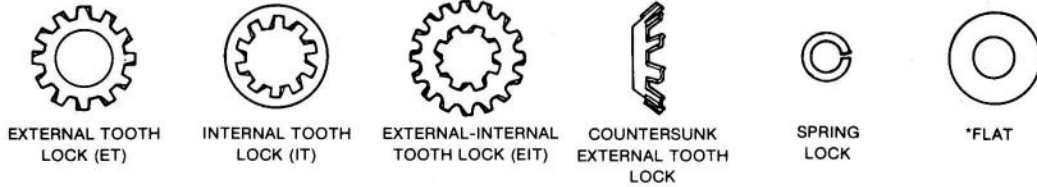

* - Flat washer dimensions given are: Inside Diameter (ID), Outside Diameter (OD) and Thickness (Thk).

BOLT AND SCREW TYPES

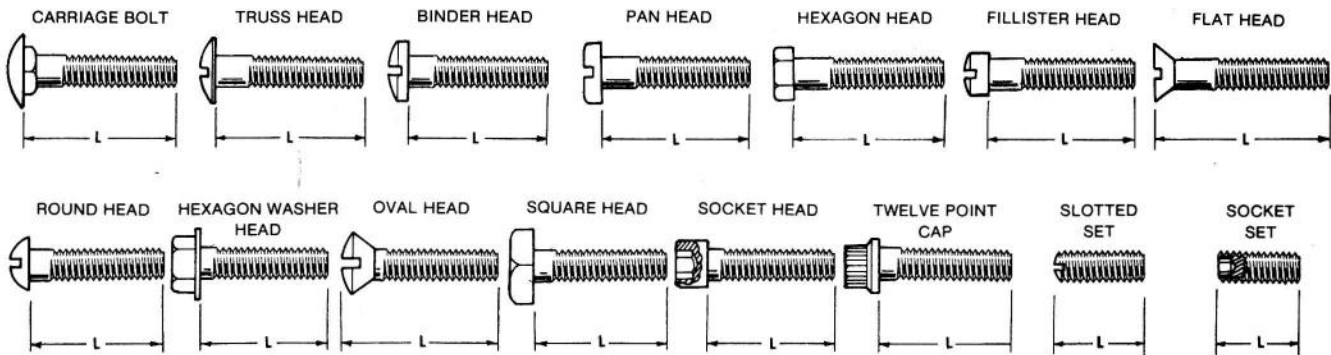

L - Measure length between these points.

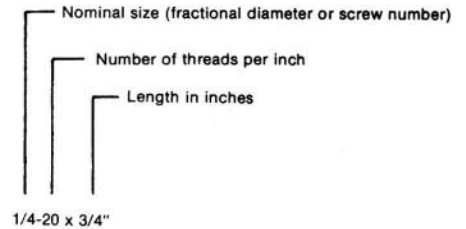
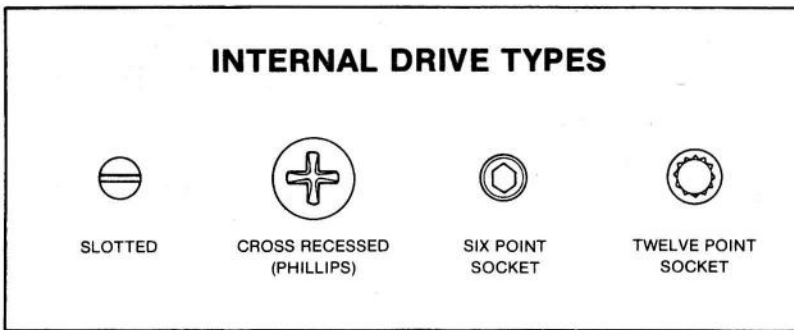

NUT TYPES



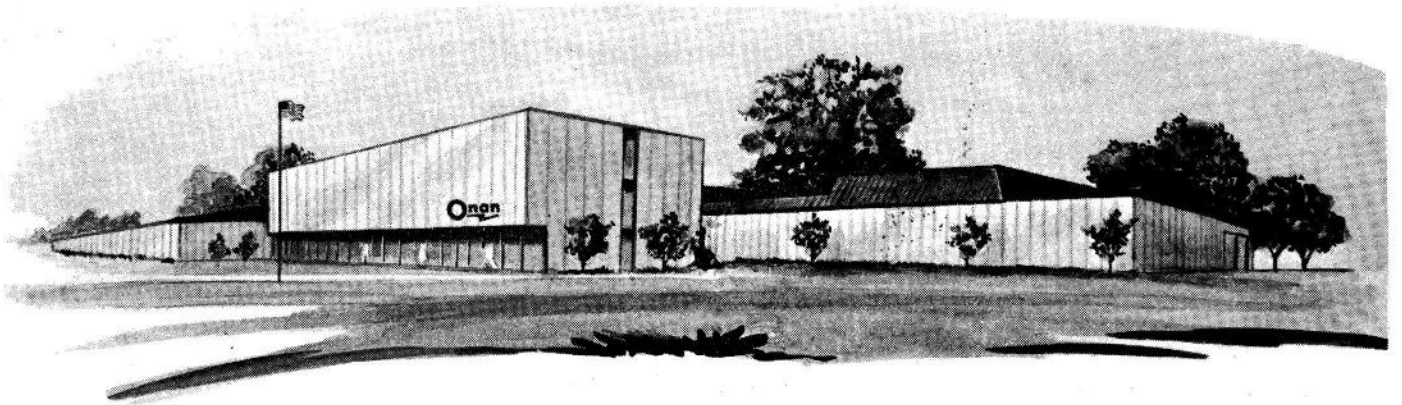

ONAN 1400 73RD AVENUE N.E. • MINNEAPOLIS, MINNESOTA 55432

